

WOOD DESTROYING PESTS AND ORGANISMS INSPECTION REPORT

BUILDING NO. 1240	STREET, CITY, STATE, ZIP Golden Gate Drive, San Diego CA 92116	Date of Inspection 5/4/2026	No. of Pages 8
-----------------------------	--	---------------------------------------	--------------------------



Termite and Pest Control (619) 462-5577
 (619) 462-1700 Fax
 3638 Bancroft Drive Spring Valley, CA 91977
 www.d-and-s-termite.com

Firm Registration No. PR 1164	Report No. 452010	Escrow No.
Ordered By: Joe Carta Realty 4134 Adams Ave Ste 101 San Diego, CA 92116 Attn: Joe Carta	Property Owner/Party of Interest Joe Carta Realty 1240 Golden Gate Drive San Diego, CA 92116	Report Sent To: Joe Carta Realty 4134 Adams Ave Ste 101 San Diego, CA 92116 Attn: Joe Carta

COMPLETE REPORT LIMITED REPORT SUPPLEMENTAL REPORT REINSPECTION REPORT

General Description: Two story, single family residence, frame and stucco construction, clay tile roof, detached garage	Inspection Tag Posted: Attic
	Other Tags Posted:

An inspection has been made to the structure(s) shown on the diagram in accordance with the Structural Pest Control Act. Detached porches, detached steps, detached decks and any other structures not on the diagram were not inspected.

Subterranean Termites Drywood Termites Fungus/Dryrot Other Findings Further Inspection

If any of above boxes are checked, it indicates that there were visible problems in accessible areas. Read the report for details on checked items.

Diagram not to scale, findings in approximate locations.

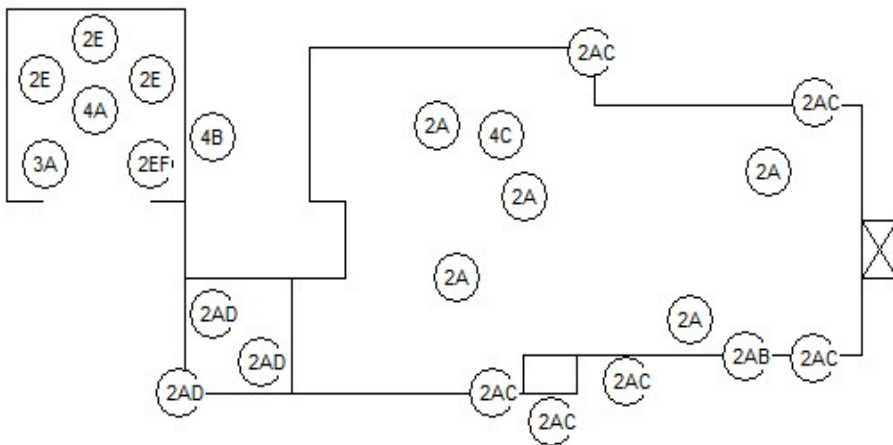

Inspected by Randy L. Krok State License No. FR 28418 Signature *Randy L. Krok*

You are entitled to obtain copies of all reports and completion notices on this property reported to the Structural Pest Control Board during the preceding two years. To obtain copies contact: Structural Pest Control Board, 2005 Evergreen Street, Suite 1500, Sacramento, California 95815.
 NOTE: Questions or problems concerning the above report should be directed to the manager of the company. Unresolved questions or problems with services performed may be directed to the Structural Pest Control board at (916) 561-8708, or (800) 737-8188 or www.pestboard.ca.gov. 43M-41 (Rev. 04/2015)

1240

Golden Gate Drive, San Diego CA 92116

5/4/2026

452010

BUILDING NO.

STREET, CITY, STATE, ZIP

INSPECTION DATE

REPORT NO.

There are certain areas of the structure, which are considered impractical for inspection: furnished interiors; inaccessible attics or portions thereof; the interior of hollow walls, spaces between a floor or porch deck and the ceiling or soffit below; stall showers over finished ceilings; such structural segments as porte cocheres, enclosed bay windows, buttresses, and similar areas to which there is no access with out defacing or tearing out lumber, masonry or finished work; built-in cabinet work; abutments, or floors beneath coverings, areas where storage conditions, heavy vegetation or locks make inspection impractical. These areas (but not limited to) are considered inaccessible and were not inspected at this time. Note Appliances and/or plumbing over finished ceilings are not water tested and we do not certify against leakage, unless otherwise noted in this report. No evidence of leaks were noted in the roof covering system however, no opinion is rendered nor is guarantee implied concerning the future water tightness of the roof. This firm makes no guarantee against any infestation, leaks, or other adverse conditions which may exist or which may develop in inaccessible areas and become visibly evident after the date of this inspection. This inspection is only of the structures indicated on the diagram. Estimate and Report good for ninety days. **The exterior surface of the roof was not inspected. If you want the water tightness of the roof determined, you should contact a roofing contractor who is licensed by the Contractors State License Board.**

NOTICE:..Reports on this structure prepared by various registered companies should list the same findings (i.e. Termite infestations, termite damage, fungus damage etc.). However recommendations to correct these findings may vary from company to company.. You have a right to seek a second opinion from another company.

This company will reinspect repairs done by others within four months of the original inspection. A charge of half the original inspection fee will be charged for each re inspection. There inspection must be done within ten(10) working days of request. The re inspection is a visual inspection and if inspection of concealed areas in desired, inspection of work in progress will be necessary. Any guarantees must be received from parties performing repairs. Section 1993.1 S.P.C.B Rules & Regulations. This company will not certify eradication of termites completed by others.

Note: This wood destroying organisms report does NOT include mold or mold like conditions. Mold is NOT a wood destroying organism and is outside the scope of this report as defined by the Structural Pest Control Board Act Rules and Regulations. If you wish your property to be inspected for mold or mold like conditions, please contact the appropriate mold professional.

Our expert opinion limited, the source of moisture may be caused by factors unknown or unseen at the time of inspection. You are advised to contact an expert in the field of moisture conditions.

NOTE: D&S Termite inspectors are not equipped with second story ladders. We do not inspect any items over (12) twelve feet above ground level. D&S Termite can not be responsible for conditions existing above this level. Should you desire an inspection above our limits, we will schedule an appointment for an inspector properly equipped to do so. There may be an additional charge of \$250.00 for this service.

This is a separated report. Which is defined as section I and section II conditions evident on the date of inspection. Section I contains items where there is visible evidence of active infestation, infection or conditions that have resulted in or from infestation of infection. Section II items are conditions deemed likely to lead to infestation or infection but where no visible evidence of such was found. Further inspection items are defined as recommendations to inspect area(s) which during the original inspection did not allow the inspector access to complete the inspection and cannot be defined as Section I or Section II. Section 1990(f)S.P.C.B. Rules & Regulations.

1240

Golden Gate Drive, San Diego CA 92116

5/4/2026

452010

BUILDING NO.

STREET, CITY, STATE, ZIP

INSPECTION DATE

REPORT NO.

2. Drywood Termites:

FINDING 2A

FINDING: Evidence of drywood termites noted in attic, windows, floors and eaves of residence, see 2A on diagram.

RECOMMENDATION 2A

RECOMMENDATION: Fumigate entire structure with lethal fumigant Sulfuryl Fluoride (VIKANE) Introduce Chloropicrin (tear gas) as needed as a warning agent. Fumigation will assure complete elimination of drywood termites, cover or clean up all visible and accessible pellets as needed. Fumigation notice and pesticide disclosure MUST be read and signed prior to injection of fumigant. Fumigation guaranteed for two years. **ALL FUMIGATIONS CANCELED LESS THAN 72 HOURS PRIOR TO SCHEDULED DATE WILL BE SUBJECT TO A CANCELLATION FEE OF 25% OF THE FUMIGATION COST.**

***** This is a Section 1 Item *****

FINDING 2B

FINDING: Evidence of drywood termite damage noted in window sill of residence, see 2B on diagram.

RECOMMENDATION 2B

RECOMMENDATION: Remove and replace or repair drywood termite damage as needed. Work completed by D&S Termite guaranteed for one year. If certification is required D&S Termite must re inspect work completed by others. D&S Termite does not guarantee work completed by others. D&S Termite & Pest Control will apply primer coat, but cannot be responsible for match of color. If during the course of repair work, fungus and/or termite damage extends into inaccessible areas, there may be an additional charge for repairs. D&S Termite & Pest Control will contact you about additional charges if any.

***** This is a Section 1 Item *****

FINDING 2C

FINDING: Evidence of drywood termite damage noted in rafter tails/eaves of residence, see 2C on diagram.

RECOMMENDATION 2C

RECOMMENDATION: Remove and replace or repair drywood termite damage as needed. Work completed by D&S Termite guaranteed for one year. If certification is required D&S Termite must re inspect work completed by others. D&S Termite does not guarantee work completed by others. D&S Termite & Pest Control will apply primer coat, but cannot be responsible for match of color. If during the course of repair work, fungus and/or termite damage extends into inaccessible areas, there may be an additional charge for repairs. D&S Termite & Pest Control will contact you about additional charges if any.

***** This is a Section 1 Item *****

FINDING 2D

FINDING: Evidence of drywood termite damage noted in patio framing and posts of residence, see 2D on diagram.

1240

Golden Gate Drive, San Diego CA 92116

5/4/2026

452010

BUILDING NO.

STREET, CITY, STATE, ZIP

INSPECTION DATE

REPORT NO.

2. Drywood Termites:

RECOMMENDATION 2D

RECOMMENDATION: Remove and replace or repair drywood termite damage as needed. Work completed by D&S Termite guaranteed for one year. If certification is required D&S Termite must re inspect work completed by others. D&S Termite does not guarantee work completed by others. D&S Termite & Pest Control will apply primer coat, but cannot be responsible for match of color. If during the course of repair work, fungus and/or termite damage extends into inaccessible areas, there may be an additional charge for repairs. D&S Termite & Pest Control will contact you about additional charges if any.

***** This is a Section 1 Item *****

FINDING 2E

FINDING: Evidence of drywood termites noted in garage of residence, see 2E on diagram.

RECOMMENDATION 2E

RECOMMENDATION: Chemically treat (Termidor) for visible and accessible drywood termite infestations as needed for control of drywood termites, cover or clean up pellets as needed. Local treatment is not intended to be an entire structure treatment method. If infestations of wood-destroying pests extend or exist beyond the area(s) of local treatment they may not be exterminated. Treatment guaranteed for one year in areas treated only.

***** This is a Section 1 Item *****

FINDING 2F

FINDING: Evidence of drywood termite damage noted in garage door jambs of residence, see 2F on diagram.

RECOMMENDATION 2F

RECOMMENDATION: Remove and replace or repair drywood termite damage as needed. Work completed by D&S Termite guaranteed for one year. If certification is required D&S Termite must re inspect work completed by others. D&S Termite does not guarantee work completed by others. D&S Termite & Pest Control will apply primer coat, but cannot be responsible for match of color. If during the course of repair work, fungus and/or termite damage extends into inaccessible areas, there may be an additional charge for repairs. D&S Termite & Pest Control will contact you about additional charges if any.

***** This is a Section 1 Item *****

3. Fungus/Dryrot:

FINDING 3A

FINDING: Fungus damage noted in garage roof sheeting/joists of residence, see 3A on diagram.

RECOMMENDATION 3A

RECOMMENDATION: Remove and replace or repair fungus damaged wood as needed. Work completed by D&S Termite guaranteed for one year. If certification is required D&S Termite must re inspect work completed by others. D&S Termite does not guarantee work completed by others. D&S Termite & Pest Control will apply primer coat, but cannot be responsible for match of color. If during the course of repair work, fungus and/or termite damage extends into inaccessible areas, there may be an additional charge for repairs. D&S Termite & Pest Control will contact you about additional charges if any.

***** This is a Section 1 Item *****

1240

Golden Gate Drive, San Diego CA 92116

5/4/2026

452010

BUILDING NO.

STREET, CITY, STATE, ZIP

INSPECTION DATE

REPORT NO.

4. Other Findings:

FINDING 4A

FINDING: Water stains noted on garage ceiling, see 4A on diagram.

RECOMMENDATION 4A

RECOMMENDATION: Owner to contact licensed contractor to inspect and repair as needed.

***** This is a Section 2 Item *****

FINDING 4B

FINDING: Moisture damage noted in small garage door of residence, see 4B on diagram.

RECOMMENDATION 4B

RECOMMENDATION: Remove and replace or repair moisture damaged wood as needed. Work completed by D&S Termite guaranteed for one year. If certification is required D&S Termite must re inspect work completed by others. D&S Termite does not guarantee work completed by others. D&S Termite & Pest Control will apply primer coat, but cannot be responsible for match of color. If during the course of repair work, fungus and/or termite damage extends into inaccessible areas, there may be an additional charge for repairs. D&S Termite & Pest Control will contact you about additional charges if any.

***** This is a Section 1 Item *****

FINDING 4C

FINDING: Water stains noted on sub floor in sub area under kitchen/bathroom of residence, see 4C on diagram.

RECOMMENDATION 4C

RECOMMENDATION: Owner to contact licensed contractor to inspect and repair as needed.

***** This is a Section 2 Item *****

NOTICE: Under the Mechanic's Lien Law any structural pest control company which contracts to do work for you, any contractor, subcontractor, laborer, supplier or other person who helps to improve your property, but is not paid for his or her work or supplies, has the right to enforce a claim against your property. This means that after a court hearing, your property could be sold by a court officer and the proceeds of the sale used to satisfy the indebtedness. This can happen even if you have paid your own contractor in full, if the subcontractor, laborer, or supplier remains unpaid.

****NOTICE**** The charge for service that this company subcontracts to another registered company may include the company's charges for arranging and administering such services that are in addition to the direct costs associated with paying the subcontractor. You may accept D&S Termite Controls bid or you contract directly with another registered company licensed to perform the work.

If you choose to contract directly with another registered company, D&S Termite Control will not in any way be responsible for any act or omission in the performance of any work that you directly contract with another to perform.

1240	Golden Gate Drive, San Diego CA 92116	5/4/2026	452010
BUILDING NO.	STREET, CITY, STATE, ZIP	INSPECTION DATE	REPORT NO.

This is not a clearance, estimate void after ninety days it may be necessary to revise prices after ninety days.

D&S Termite & Pest Control will waive inspection fee if authorized to do work.

NOTE: Itemized cost estimates are valid only if **ALL** work is completed by D&S Termite Control. Prices may vary if partial items are requested, call office for details.

*****NOTICE***ANY REQUEST TO ALTER OR CORRECT ANY PART OF THIS REPORT IS SUBJECT TO A \$30.00 ADMINISTRATIVE FEE, PAYABLE AT TIME OF REQUEST.*****

AREAS INSPECTED:

- 1-SUB AREAS (soil conditions, accessibility, etc.)-moist/mostly inaccessible due to construction
- 2-STALL SHOWERS(water tested? leaks?)-overtub
- 3- FOUNDATIONS(type, relation to grade, etc.)-concrete
- 4-PORCHES-STEPS-concrete
- 5-VENTILATION(type, relation to grade, etc.)-adequate
- 6-ABUTMENTS(stucco walls, columns, arches, etc.)-none
- 7-ATTICS(accessibility, insulation, etc.)-partly inaccessible due to construction
- 8-GARAGES(type, accessibility, etc.)-detached
- 9-DECKS/PATIOS-attached patio
- 10-INTERIOR-inspected
- 11-EXTERIOR-inspected

28M PI

1240

Golden Gate Drive, San Diego CA 92116

5/4/2026

452010

BUILDING NO.

STREET, CITY, STATE, ZIP

INSPECTION DATE

REPORT NO.

SECTION 1

SECTION 2

FURTHER INSPECTION

2A \$ 2100.00

2B \$ 4000.00

2C See 2B

2D See 2B

2E \$ 685.00

2F See 2B

3A See 2B

4B See 2B

4A OTCC

4C See 4A

Proposed Cost Section 1: \$6,785.00

Proposed Cost Section 2: \$0.00

Proposed Cost Fur. Insp: \$0.00

