

SWIMLIFE OWNER'S MANUAL

Enhancing Life



SWIMLIFE

SWIMSPAS

FOR AN EXTRAORDINARY LIFE

swimlifewimspas.com



Contents subject to change without notice

2024

Models Covered	Domestic Model Codes	Export Model Codes
12SL Swim Fun	SS-PS-SFN	SSE-PS-SFN
14SL Swim Fit	SS-JS-SF	SSE-JS-SF
14SL Swim Expert	SS-JS-SE	SSE-JS-SE
17SL Swim Fit	SS-AS-SF	SSE-AS-SF
17SL Swim Expert	SS-AS-SE	SSE-AS-SE
19SL Swim Fit	SS-DS-SF	SSE-DS-SF
19SL Swim Expert	SS-DS-SE	SSE-DS-SE

TABLE OF CONTENTS

Important User Safety Instructions	
Warnings	5
Hyperthermia	6
Important Electrical Safety Instructions	7-9
G.F.C.I./R.C.D. Application Guideline & Wire Size	7
North America G.F.C.I. Installation Diagram	8
Europe R.C.D. Installation Diagram	9
Filling, Checking and Starting your Hot Tub	10-11
Pump Priming/Releasing an Air Lock	10-11
Swimlife Control Systems	12-19
Swim Fun Controls	12
Swim Fun Series Programming	13-15
Swim Fit/Swim Expert Series	16-23
Dualstream Spa Controls	17
Swim Fit Controls	18
Swim Expert Controls	19
Programming	20-23
Swim Sync System	24-34
Standby Mode	35
Drain Mode	35
Topside Panel Display Messages	35
Swimfall Waterfall Control Filter	35
Wave Rider Current Control	36-37
Swimlife Clear Blue Mineral System	38-41
Auxiliary Heater Bypass Loop	41

NOTE: Product specifications, warnings and labels are subject to change without notice. This user's manual should be used as a guide only. For further information, please contact your independent Swimlife dealer.

TABLE OF CONTENTS

Water Balance	
General Overview	42
Initial Fill	42
Glossary of Common Water Maintenance Terms	43
Water Balance Summary for your Swim Spa (chart)	43
Water Balance Troubleshooting	44
Routine Hot Tub Maintenance	
Daily, Weekly, Monthly, Quarterly	45
Cleaning the Skimmer Basket	45
Safety Hard Cover	45
Cartridge Filter, Removal, Cleaning, Re-installation	46
Cleaning the Acrylic Surface	46
Changing your Swim Spa Water	47
Draining your Swim Spa Water	47
Water Softeners	47
TriChlor Water Treatment	47
Soft Stride Floor System	48
Care of Stainless Steel	48
Winterizing your Swimlife Swimspa	49
General Troubleshooting	50
What to do in the event of	
Power Fluctuations	50
Cold Weather Power Failure	50
Wiring Diagrams (in.ye)	51-54

NOTE: Product specifications, warnings and labels are subject to change without notice. This user's manual should be used as a guide only. For further information, please contact your independent Swimlife dealer.

SAVE THESE INSTRUCTIONS

IMPORTANT SAVE THESE INSTRUCTIONS

Your physiological response to hot water is subjective and depends on your age, health, and medical history. If you don't know your tolerance to hot water, or if you get a headache, or become dizzy or nauseous when using your hot tub, get out and cool off immediately.



WARNING

1. CHILDREN SHOULD NOT USE SPAS OR HOT TUBS WITHOUT ADULT SUPERVISION.
2. DO NOT USE SPAS OR HOT TUBS UNLESS ALL SUCTION GUARDS ARE INSTALLED TO PREVENT BODY AND HAIR ENTRAPMENT.
3. PEOPLE USING MEDICATIONS AND/OR HAVING ANY ADVERSE MEDICAL HISTORY SHOULD CONSULT A PHYSICIAN BEFORE USING A SPA OR HOT TUB.
4. PEOPLE WITH INFECTIOUS DISEASES SHOULD NOT USE A SPA OR HOT TUB.
5. TO AVOID INJURY, EXERCISE CARE WHEN ENTERING OR EXITING THE SPA OR HOT TUB.
6. DO NOT USE DRUGS OR ALCOHOL BEFORE OR DURING THE USE OF A SPA OR HOT TUB, TO AVOID UNCONSCIOUSNESS AND POSSIBLE DROWNING.
7. PREGNANT OR POSSIBLE PREGNANT WOMEN SHOULD CONSULT A PHYSICIAN BEFORE USING A SPA OR HOT TUB.
8. WATER TEMPERATURE IN EXCESS OF 38°C (100°F) MAY BE INJURIOUS TO YOUR HEALTH.
9. BEFORE ENTERING THE SPA OR HOT TUB, MEASURE THE WATER TEMPERATURE WITH AN ACCURATE THERMOMETER.
10. DO NOT USE A SPA OR A HOT TUB IMMEDIATELY FOLLOWING STRENUOUS EXERCISE.
11. PROLONGED IMMERSION IN A SPA OR HOT TUB MAY BE INJURIOUS TO YOUR HEALTH.
12. DO NOT PERMIT OR USE ELECTRIC APPLIANCES (SUCH AS LIGHT, TELEPHONE, RADIO OR TELEVISION) WITHIN 1.5M (5FT) OF THIS SPA OR HOT TUB.
13. CHILDREN SHOULD NOT ENTER A HOT TUB WHERE THE WATER TEMPERATURE EXCEEDS BODY TEMPERATURE (37°C / 98.6°F).
14. DO NOT ALLOW CHILDREN TO SUBMERGE THEIR HEAD UNDER WATER.
15. NEVER OPERATE THE HOT TUB PUMP AT HIGH SPEED WITHOUT HAVING ALL SUCTION AND RETURN LINES OPEN.
16. ALWAYS KEEP THE HARDCOVER INSTALLED AND LOCKED WHEN THE HOT TUB IS NOT IN USE.
17. TEST THE GFCI (GROUND FAULT CIRCUIT INTERRUPTER) MONTHLY.
18. POST EMERGENCY PHONE NUMBERS FOR POLICE, FIRE DEPARTMENT, AND AMBULANCE AT THE NEAREST PHONE.
19. TO REDUCE THE RISK OF INJURY
 - THE WATER IN A SPA SHOULD NEVER EXCEED 40°C (104°F). WATER TEMPERATURES BETWEEN 38°C (100°F) AND 40°C (104°F) ARE CONSIDERED SAFE FOR A HEALTHY ADULT. LOWER WATER TEMPERATURES ARE RECOMMENDED FOR YOUNG CHILDREN AND WHEN SPA USE EXCEEDS 10 MINUTES.
 - SINCE EXCESSIVE WATER TEMPERATURES HAVE A HIGH POTENTIAL FOR CAUSING FETAL DAMAGE DURING THE EARLY MONTHS OF PREGNANCY, PREGNANT OR POSSIBLY PREGNANT WOMEN SHOULD LIMIT SPA WATER TEMPERATURES TO 38°C (100°F).
 - BEFORE ENTERING A SPA, THE USER SHALL MEASURE THE WATER TEMPERATURE SINCE THE TOLERANCE FOR WATER TEMPERATURE-REGULATING DEVICES VARIES.
 - THE USE OF ALCOHOL, DRUGS, OR MEDICATION BEFORE OR DURING SPA USE MAY LEAD TO UNCONSCIOUSNESS, WITH THE POSSIBILITY OF DROWNING.
 - OBESE PERSONS AND PERSONS WITH A HISTORY OF HEART DISEASE, LOW OR HIGH BLOOD PRESSURE, CIRCULATORY SYSTEM PROBLEMS OR DIABETES SHOULD CONSULT A PHYSICIAN BEFORE USING A SPA.
 - PERSONS USING MEDICATION SHOULD CONSULT A PHYSICIAN BEFORE USING A SPA SINCE SOME MEDICATION MAY INDUCE DROWSINESS WHILE OTHER MEDICATION MAY EFFECT HEART RATE, BLOOD PRESSURE AND CIRCULATION.

SAVE THESE INSTRUCTIONS
IMPORTANT SAVE THESE INSTRUCTIONS

Your physiological response to hot water is subjective and depends on your age, health, and medical history. If you don't know your tolerance to hot water, or if you get a headache, or become dizzy or nauseous when using your hot tub, get out and cool off immediately.



CAUTION

1. MAINTAIN WATER CHEMISTRY IN ACCORDANCE WITH THE MANUFACTURER'S INSTRUCTIONS.



DANGER

1. RISK OF ACCIDENTAL DROWNING. EXTREME CAUTION MUST BE EXERCISED TO PREVENT UNAUTHORIZED ACCESS BY CHILDREN. TO AVOID ACCIDENTS, ENSURE THAT CHILDREN CAN'T USE THE SPA UNLESS THEY ARE SUPERVISED AT ALL TIMES.
2. RISK OF INJURY. THE SUCTION FITTINGS IN THIS SPA ARE SIZED TO MATCH THE SPECIFIC WATER FLOW CREATED BY THE PUMP. SHOULD THE NEED ARISE TO REPLACE THE SUCTION FITTINGS OR THE PUMP, BE SURE THAT THE FLOW RATES ARE COMPATIBLE. NEVER OPERATE THE SPA IF THE SUCTION FITTINGS ARE BROKEN OR MISSING. NEVER REPLACE A SUCTION FITTING WITH ONE RATED LESS THAN THE FLOW RATE MARKED ON THE ORIGINAL SUCTION FITTING.
3. RISK OF ELECTRIC SHOCK. INSTALL AT LEAST 1.5M (5FT) FROM ALL METAL SURFACES. AS AN ALTERNATIVE, A SPA MAY BE INSTALLED WITHIN 1.5M (5FT) OF METAL SURFACES IF EACH METAL SURFACE IS PERMANENTLY CONNECTED BY A MINIMUM 8 AWG (8.4 mm²) SOLID COPPER CONDUCTOR TO THE WIRE CONNECTOR ON THE TERMINAL BOX THAT IS PROVIDED FOR THIS PURPOSE.
4. RISK OF ELECTRIC SHOCK. DO NOT PERMIT ANY APPLIANCE, SUCH AS A LIGHT, TELEPHONE, RADIO, OR TELEVISION, WITHIN 1.5M (5FT) OF THE SPA.

HYPERTHERMIA

Since your hot tub can be set to reach temperatures of 40°C (104°F), users should be aware that extended submersion in water that exceeds normal body temperature can lead to hyperthermia.

The causes, symptoms and effects of hyperthermia may be described as follows:

Hyperthermia occurs when the internal temperature of the body reaches several degrees above the normal body temperature of 37°C (98.6°F). The symptoms of hyperthermia include drowsiness, lethargy, and an increase in the internal temperature of the body. The effects of hyperthermia include:

- Unawareness of impending hazard
- Failure to perceive heat
- Failure to recognize the need to exit the hot tub
- Physical inability to exit the hot tub
- Fetal damage in pregnant woman
- Unconsciousness resulting in the danger of drowning

If you sense any of the symptoms of hyperthermia, safely exit the hot tub immediately.

WARNING



THE USE OF ALCOHOL, DRUGS OR MEDICATION CAN SIGNIFICANTLY INCREASE THE RISK OF FATAL HYPERTHERMIA.

**NEVER ALLOW DIVING OR JUMPING
IN YOUR SWIM SPA**

IMPORTANT ELECTRICAL SAFETY INSTRUCTIONS

SAFETY COMES FIRST. WHEN INSTALLING & USING THIS ELECTRICAL EQUIPMENT, BASIC SAFETY PRECAUTIONS MUST ALWAYS BE FOLLOWED!

1. **READ AND FOLLOW ALL INSTRUCTIONS.**
2. Electrical installation must be completed by a qualified electrician in accordance with all National, Regional and Local Codes and Regulations in effect at the time of installation.
3. Connect only to a dedicated circuit protected by a class 'A' two-pole ground fault circuit interrupter (GFCI)
4. **Use copper conductors only!**
5. The hot tub equipment and all electrical plugs, outlets and lights within 1.5m (5ft) of the unit must be G.F.C.I protected. Consult your electrician or local electrical authority for further details.
6. A green colored terminal or a terminal marked "G", "GR", "Ground", or "Grounding" is located inside the supply terminal box or compartment. To reduce the risk of electric shock, this terminal must be connected to the grounding means provided in the electric supply service panel with a continuous copper wire equivalent in size to the circuit conductors supplying the equipment.
7. At least two lugs marked "**BONDING LUGS**" are provided on the external surface or on the inside of the supply terminal box or compartment. To reduce the risk of electric shock, connect the local common bonding grid in the area of the hot tub to these terminals with an insulated or bare copper conductor not smaller than No.6 AWG (Canada/Europe) / No.8 AWG (USA).
8. All field installed metal components such as rails, ladders, drains or other similar hardware within 3 m (10 ft) of the hot tub shall be bonded to the equipment grounding bus with copper conductors not smaller than No.6 AWG.

G.F.C.I./R.C.D. APPLICATION GUIDE FOR SWIMLIFE SWIM SPA SERIES

NORTH AMERICA	
Swimfun	50A
Swimstream / Aquastream Swim Fit	50A
Dualstream Swim Fit	40A spa 50A swim
Swimstream / Aquastream Swim Expert	60A
Dualstream Swim Expert	40A spa 60A swim
EUROPE (single phase)	
Swimfun	40A
Swimstream / Aquastream Swim Fit	40A
Dualstream Swim Fit	20A spa 40A swim
Swimstream / Aquastream Swim Expert	40A
Dualstream Swim Expert	20A spa

IMPORTANT NOTE:

- This guide is for standard installations where the wire run is 15 m (50 ft.) or less. For longer wire runs, consult a qualified electrician.

WIRE SIZE

NORTH AMERICA

- The minimum wire size for systems that require a 40A GFCI is # 8/3 c/w ground (also referred to as # 8 gauge / 4 conductor).
- The minimum wire size for systems that require a 50A GFCI is # 8/3 c/w ground (also referred to as # 8 gauge / 4 conductor).
- The minimum wire size for systems that require a 60A GFCI is # 6/3 c/w ground (also referred to as # 6 gauge / 4 conductor).

EUROPE

Standards for amperage breakers may vary from country to country in the CE controlled area. Please consult your local installer for advice on breaker level and wire specifications. Some examples are below:

- Breaker of 13A – wire must be 1.5 mm²
- Breaker of 16A – wire must be 2.5 mm²
- Breaker of 20A – wire must be 4.0 mm²
- Breaker of 32A – wire must be 6.0 mm²

NOTE: Please consult your applicable electrical codes related to the size of conductors as they may vary from what is stated above. Take into consideration the length of cable as well and increase as required.

NORTH AMERICA – GFCI INSTALLATION



NOTICE

Installation of the GFCI - Circuit Breaker, including ampere sizing and selection of conductor size and type, must be performed by a qualified electrician in accordance with the National Electrical Code, or the Canadian Electrical Code, and all Federal, State/Provincial and local codes and regulations in effect at the time of installation. Swimlife highly recommends the use of a new Siemens GFCI breaker for all of its products. Other GFCI's and older Siemens' GFCI's may have tripping issues.

240 VOLT 60Hz SWIMSPA SINGLE GFCI WIRING (MAIN ONLY)

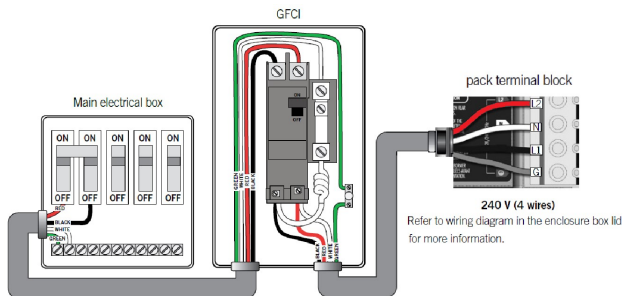

240 VOLT 60 Hz SWIMSPA SINGLE GFCI WIRING MAIN / AUXILIARY HEATER

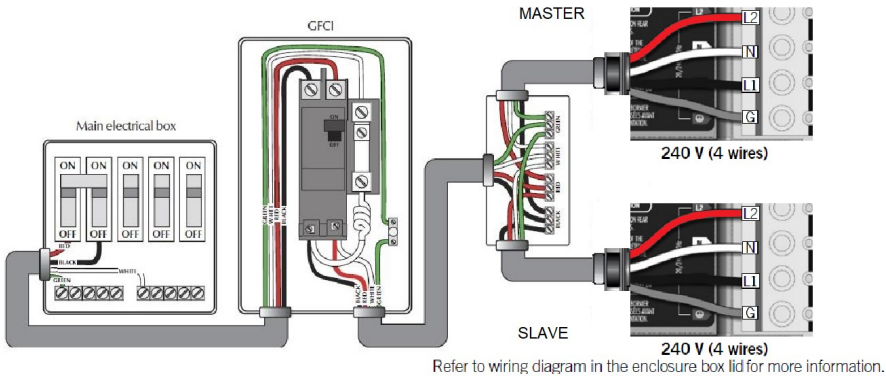

240 VOLT 60 Hz SWIMSPA DUAL GFCI WIRING MAIN / AUXILIARY HEATER

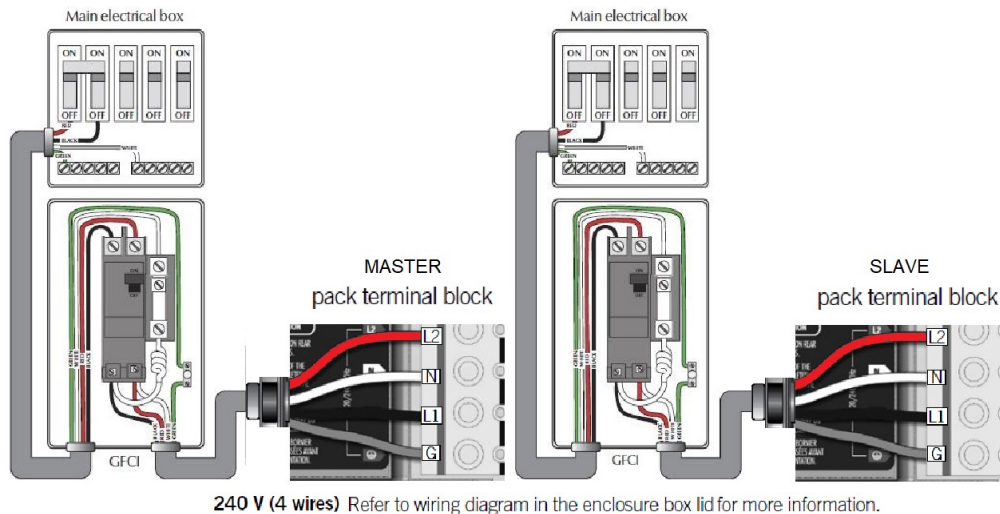

EUROPE – R.C.D. INSTALLATION - TYPICAL



NOTICE

Important Note: Installation of the R.C.D. - Circuit Breaker, including ampere sizing and selection of conductor size and type, must be performed by a qualified electrician in accordance with National, Regional and Local Codes and Regulations

230 VOLT 50 Hz SINGLE PHASE RCD WIRING

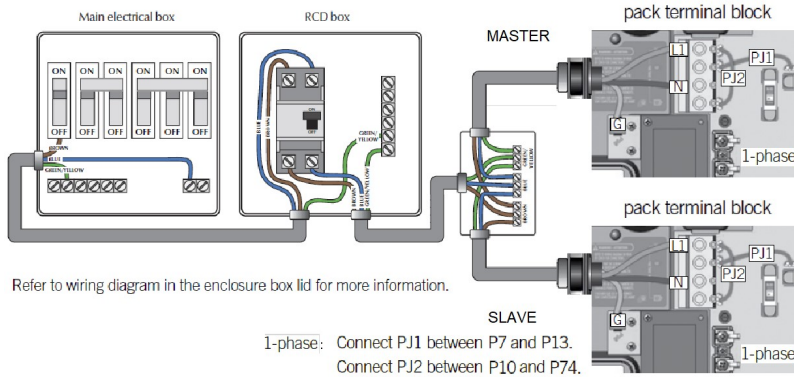

230 VOLT 50 Hz DUAL PHASE RCD WIRING

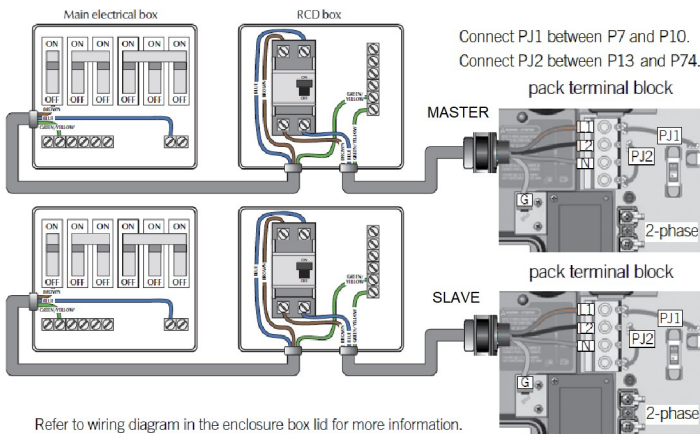

230 VOLT 50 Hz THREE PHASE RCD WIRING

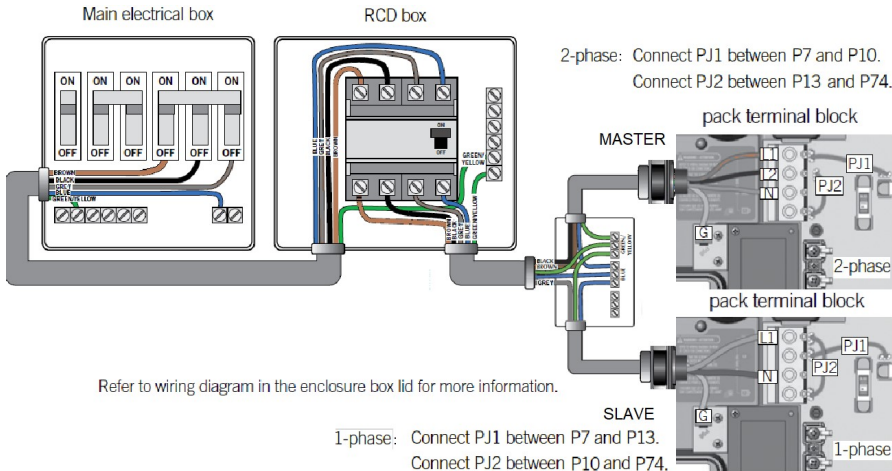

FILLING, CHECKING AND STARTING YOUR SWIM SPA—ALL OTHER SWIMSPAS

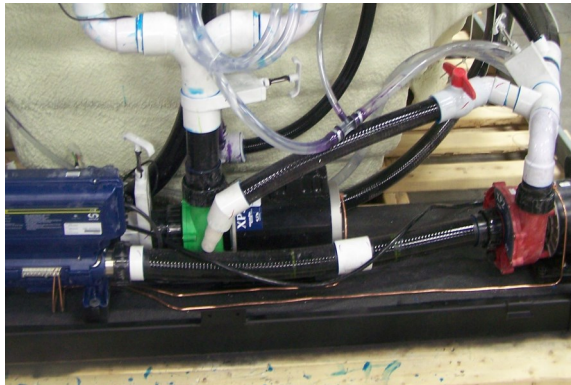

PROPER WATER LEVEL

FILLING

- When adding water for the first time, the swim spa should be filled through the skimmer opening (helps to prevent air locks) using a standard garden hose, turning the tap on slowly to prevent damage to the surface by a jerking hose connection.
- Pull up the handles on the intake and return gate valves and clip on the stem locks. (handles are pulled up when valves are open and pushed down when valves are closed).
- Ensure the drain valve is closed.
- Ensure that all jets are open.
- Fill the swim spa to the recommended level as indicated.

CHECKING

Although your swim spa was thoroughly water-tested in the factory, some loosening of fittings can occur during shipping. Before any decking, tiling or carpeting is completed around the installation, fill and operate your hot tub to test for leaks (this ensures easy access and inexpensive correction). Check all union connections and plumbing for minor leaks. In the event of a leak, ensure all union connections and pump plugs are tight and all o-rings/gaskets are in place.

Also check the tightening of the screws and all the electrical connections which could loosen during shipping.

STARTING

Before applying voltage to power-up your swim spa, it is very important that you understand the sequence of events that occur when the system is activated in order that the pump can be primed efficiently and damage to the system can be avoided.

- Turn the main power “on” at your electrical panel.
- Follow the control instructions for your particular model swim spa to put the pump into low speed.

See section **SWIMLIFE CONTROL SYSTEMS**

PUMP PRIMING/RELEASING AN AIR LOCK

- On some systems a message will appear on the display indicating that the system is in **PUMP PRIMING MODE**. This mode will last for 4 to 5 minutes before automatically entering the normal operation mode. See complete details for your spa in section **SWIMLIFE CONTROL SYSTEMS**.

When the pump is located below water level, the water should start circulating immediately. If the motor works but if you do not notice water circulation within the first 15 seconds, the pump may require priming due to trapped air (referred to as an ‘air lock’). To prime (inset 2), open the hose-bib to allow trapped air to escape. Close as soon as the water flow from the jets becomes regular. If the pumps have not primed after 2 minutes, and water is not flowing from the jets, **DO NOT** allow the pumps to continue to run. Turn power off at the main house panel (or GFCI) and try releasing the air again by loosening the union on the discharge side of the pump(s) while the motor is not running. Turn the power back on. If the pump(s) does not prime after 15 seconds, sometimes momentarily turning the pump(s) off and on will help the system to prime (note: do not do this more than 5 times). Repeat if necessary.

• **Important:** Under NO circumstances should the pump(s) be allowed to operate without priming beyond 5 minutes, as this may not only cause unwarrantable damage to the pump, it may also cause the control system to go into an overheat condition.

Definition: ‘Priming’ a pump is a term used to describe the process in which air trapped in the plumbing and pump wet end (referred to as an ‘air lock’) is released, allowing the pump to move water efficiently through the plumbing system and to the jets.

RELEASING AIR TRAPPED IN FILTER...

...THROUGH THE
PUMP UNION

RELEASING AN AIR LOCK...



- When the pump starts circulating, it will be necessary to release trapped air in the filter. Carefully loosen the air vent valve counter-clockwise until there is the hissing sound of air escaping. Once there is a steady stream of water, close the vent valve, ensuring that the o-ring does not become pinched.
- Turn the Hydrotherapy pump(s) on and re-check for leaks. The control system will automatically return the pump(s) off after 15 minutes.
- Adjust the hot tub heat control at the topside panel to the desired water temperature.
- Adjust water balance (pH, TA, calcium hardness) to recommended levels and add sanitizer once the water temperature reaches 20°C (68°F).

See section WATER BALANCE

- Keep insulated safety hard cover on the hot tub, and the air controls closed during the entire heat up process.

NOTE:

In order to prevent damage to your pillows caused by the gassing effect of the chemicals, we do recommend to remove them when the spa is not in use. By removing them you will extend considerably the life length of your pillows. We do design ours pillows to be removed easily in order to make sure they will not remain in the spa when it's not in use.

SWIMLIFE SWIM SPA SERIES CONTROL SYSTEMS



INITIAL START-UP

Before applying voltage to power-up your hot tub, it is very important that you understand the sequence of events that occur when the system is activated in order that the pump(s) can be primed efficiently and damage to the system can be avoided.

PROGRAM MENU

The program menu is accessible by holding down the Light Key for 5 seconds. In the Program Menu the following parameters can be set: clock, filter or purge cycles, economy mode and temperature units. While in the program menu, use the Up and Down keys (Up/ Down Key) to adjust the parameters and the Light key to jump to the next parameter. The changes will be saved after the confirmation of the last parameter only. If there is no action taken for 10 seconds, the system will exit the program menu without saving any changes.

SETTING THE CLOCK TIME

Enter the program menu by holding down the Light Key for 5 seconds. The display will show the current clock setting with the hour flashing. Use the arrow keys to adjust the hour. Press the Light Key to adjust the minutes. Press the light key to jump to the next parameter or to the end of the parameters to save the time.

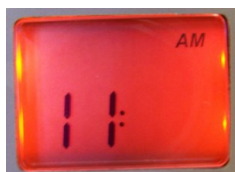

TEMPERATURE CONTROL FUNCTIONALITY AND ADJUSTMENT



After you exit the programming mode your hot tub will automatically heat to the factory preset default temperature of 38°C (100°F).

The temperature shown on the screen is the current water temperature. Use the UP and DOWN buttons to set the desired temperature.

The set point icon will appear at the top of the screen. After 3 seconds without any change to the set temperature value, the keypad will resume the normal display.

STANDBY MODE

Pressing the JET key for 5 seconds will enable the Standby Mode. This mode allows you to stop all outputs including automatic functions such as the filter cycle, heat request and smart winter mode for 30 minutes to perform quick spa maintenance. When active, the display will toggle between the "OFF" message, the clock and water temperature.



SWIMLIFE SWIM SPA SERIES CONTROL SYSTEMS
NORTH AMERICA / EUROPE
SWIMFUN CONTROLS

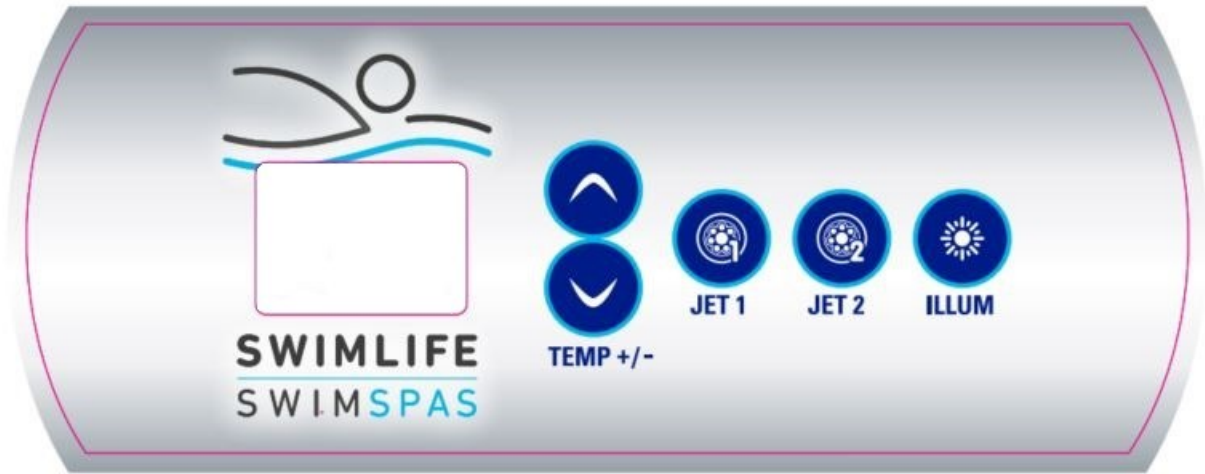

KEYPAD FUNCTIONS AND DISPLAY ICONS



JET 1 KEY WHICH
CONTROLS PUMP 1



JET 2 KEY WHICH
CONTROLS PUMP 2



LIGHT KEY WHICH
CONTROLS THE
LIGHTING



TEMPERATURE
UP KEY



TEMPERATURE
DOWN KEY

SWIMLIFE SWIM SPA SERIES CONTROL SYSTEMS

NORTH AMERICA / EUROPE

SWIMFUN SERIES

**PROGRAMMING THE
FILTER / PURGE CYCLES**



The filter cycle menu consists of the following parameter: the start time (FS), the duration (Fd), and the frequency (FF).

NOTE: A filter cycle consists of starting all the pumps and blower (if equipped) in high speed for 1 minute (purge step) then the pump associated with the filter cycle will run in low speed for the remaining duration of the filter cycle (clean up step).

SETTING THE FILTER CYCLE



After you have programmed the clock, the next parameter is the filter cycle start time. The display will show FSxx, with "xx" representing the starting hour of the cycle. Use the arrow keys to adjust the hours. Use the Light Key to jump to the next parameter, filter duration (Fd).



The display will show Fdxx, with "xx" representing the duration in hours of the filter cycle. Use the arrow keys to adjust the duration. Use the Light Key to jump to the next parameter, filter frequency (FF).



The display will show FFxx, with "xx" representing the number of cycles per day. Use the arrow keys to adjust the frequency. Use the Light Key to jump to the next parameter, economy mode (EP)

This mode allows you to lower the temperature set point of the spa by 20F (11C) during a certain period of the day.



The display will show Epx, with "x" representing the state of the programming (0 = disabled, 1 = enabled). Use the arrow keys to enable or disable the economy mode. Use the light key to jump to the next parameter, economy start time (ES).

When the Economy mode in ON, the display will toggle between the "Eco" message, the time and the water temperature.



The display will show ESxx, with "xx" representing the hour at which the economy mode will become active. Use the arrow keys to adjust the hour. Use the Light Key to jump to the next parameter, economy duration (Ed).



The display will show Edxx, with “xx” representing the duration in hours of the economy mode. Use the arrow keys to adjust the hour. Use the Light Key to jump to the next parameter, temperature unit.



Water temperature can be displayed in either Fahrenheit (°F) or Celsius (°C). The display will show °F or °C. Use the arrow keys to change the setting. Use the Light Key to save all the parameters.

SMART WINTER MODE

Smart Winter Mode protects your system from the cold by turning the pumps on several times a day to prevent water from freezing in the pipes. The Smart Winter Mode indicator turns on when in this mode of operation. If the temperature drops to 4°C (39°F) within the heater chamber, the system automatically activates the pump to provide freeze protection. The pump will operate until the temperature reaches 5°C (41°F) before returning to normal system mode.

COOLING DOWN

After heating the spa water to the desired set point, the heater is turned off, but the filtration pump remains on for a certain amount of time to ensure adequate cooling of the heating element in order to prolong the useful life of the heater. The heater icon flashes during this time.

PUMP 1 FUNCTION



Press this key (JET 1) to activate the pump

1st press – low speed (**indicator light flashes**)

2nd press – high speed (**indicator light on solid**)

3rd press – turns off (**indicator light off**)

PUMP 2 FUNCTION



Press this key (JET 2) to activate the pump

1st press – high speed (**indicator light on solid**)

2nd press – turns off (**indicator light off**)

PUMPS AUTOMATIC TIME-OUT

Time out – 15 minutes

LIGHT FUNCTION



Press this pad to activate the light

1st press: rotating colours

2nd press: solid blue colour

3rd press: solid green colour

4th press: solid red colour

Note: Pressing the light key in intervals less than five seconds will scroll to the next colour. Once you have selected the colour another press will turn the light off.

LIGHT AUTOMATIC TIME-OUT

Time out – 60 minutes

SWIMLIFE SWIM SPA SERIES CONTROL SYSTEMS

NORTH AMERICA / EUROPE

SWIM FIT / SWIM EXPERT SERIES



INITIAL START-UP

Before applying voltage to power-up your hot tub, it is very important that you understand the sequence of events that occur when the system is activated in order that the pump(s) can be primed efficiently and damage to the system can be avoided.

At initial power-up, the system will show the following screen.

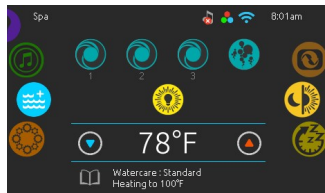

The keypad does store the date and time for a limited time so when the system starts up after a loss of power it may be necessary to reprogram the time and date if the power down duration is greater than 48 hours.

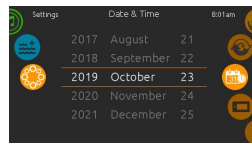
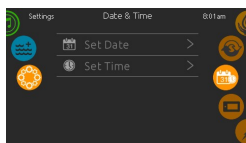

PROGRAMMING THE DATE AND TIME

Here you can adjust the time format (AM/PM or 24h), day of the week and time. Use the icons to choose the setting that you want to adjust and select it by scrolling through the menu.

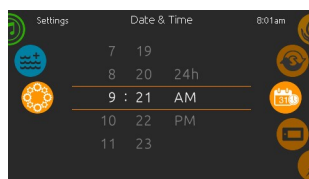

TEMPERATURE CONTROL FUNCTIONALITY AND ADJUSTMENT

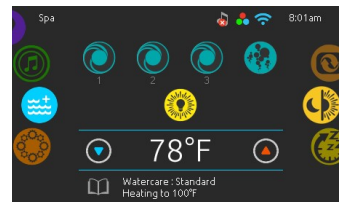

After you exit the programming mode your hot tub will automatically heat to the factory preset default temperature of 38°C (100°F).

The temperature shown in white on the screen is the current water temperature. Use the UP and DOWN icon to set the desired temperature.

The set point will appear in blue on the screen. After 3 seconds without any change to the set temperature value, the keypad will resume the normal display of messages.

When the set value is lower than the current temperature “Cooling to XX”F (°C)” will appear. When the value is set higher than the current temperature, “Heating to XX”F (°C)” will be indicated.

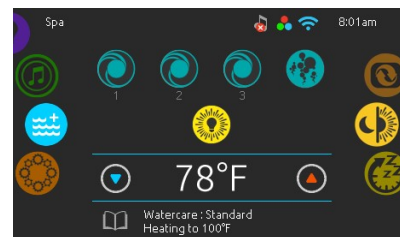

SWIMLIFE SWIM SPA SERIES CONTROL SYSTEMS
 NORTH AMERICA / EUROPE
 DUALSTREAM SPA CONTROLS



KEYPAD FUNCTIONS AND DISPLAY ICONS



SPA
FUNCTION
KEY



PUMP 1
FUNCTION
KEY

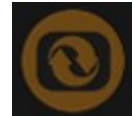

INVERT
DISPLAY
KEY



SETTINGS
FUNCTION
KEY



LIGHT
FUNCTION
KEY



DAY
NIGHT
CONTRAST



QUICK START /
STOP KEY



TEMP
UP
KEY



SLEEP
MODE
KEY



TEMP
DOWN
KEY

SWIMLIFE SWIM SPA SERIES CONTROL SYSTEMS
 NORTH AMERICA / EUROPE
 SWIMFIT CONTROLS



KEYPAD FUNCTIONS AND DISPLAY ICONS

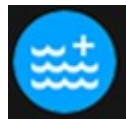

**SPA
FUNCTION
KEY**



**SETTINGS
FUNCTION
KEY**



**QUICK START /
STOP KEY**



**PUMP 1
FUNCTION
KEY**



**PUMP 2
FUNCTION
KEY**



**LIGHT
FUNCTION
KEY**



**TEMP
UP
KEY**

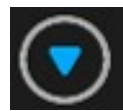

**TEMP
DOWN
KEY**

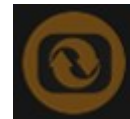

**INVERT
DISPLAY
KEY**



**DAY
NIGHT
CONTRAST**



**SLEEP
MODE
KEY**

SWIMLIFE SWIM SPA SERIES CONTROL SYSTEMS

NORTH AMERICA / EUROPE

SWIM EXPERT CONTROLS



KEYPAD FUNCTIONS AND DISPLAY ICONS

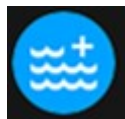

SPA
FUNCTION
KEY



SETTINGS
FUNCTION
KEY



QUICK START /
STOP KEY



PUMP 1
FUNCTION
KEY



PUMP 2
FUNCTION
KEY



PUMP 3
FUNCTION
KEY



LIGHT
FUNCTION
KEY



TEMP
UP
KEY



TEMP
DOWN
KEY

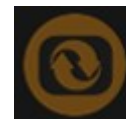

INVERT
DISPLAY
KEY



DAY
NIGHT
CONTRAST



SLEEP
MODE
KEY

PUMP 1 FUNCTION

Press this pad to activate the pump

- 1st press – low speed (**icon rotates slow**)
- 2nd press – high speed (**icon rotates fast**)
- 3rd press – turns off

PUMP AUTOMATIC TIME-OUT

Low and High speed – 15 minutes

PUMP 2 & 3FUNCTION (if included)

Press this pad to activate the pump

- 1st press – high speed (**icon rotates fast**)
- 2nd press – turns off

PUMP AUTOMATIC TIME-OUT

High speed – 15 minutes

LIGHT FUNCTION

Press this pad to activate the light

- 1st press: rotating colours
- 2nd press: solid blue colour
- 3rd press: solid green colour
- 4th press: solid red colour

Note: Pressing the light key in intervals less than three seconds will scroll to the next colour. Once you have selected the colour another press will turn the light off.

LIGHT AUTOMATIC TIME-OUT

Time out – 60 minutes

SETTINGS KEY

From the home page you can access the Settings, where you will find:

- Water Care
- Maintenance
- Day & Time
- Keypad Settings
- Miscellaneous
- Electrical Configuration
- About

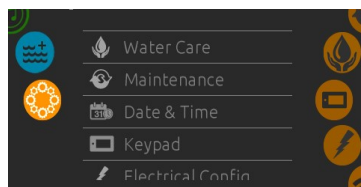

Use the icon keys to scroll up and down in the list. To select an option, press the text.

At any point you can press the Spa Function icon to return to the home screen.



WATER CARE

The Water Care section will help you set up your ideal filtration and heating settings. Choose from Away, Beginner, Energy Savings, Super Energy Savings and Weekender, depending on your needs.

Use the Light key to choose your setting. A checkmark will appear on the selected icon to confirm.

In Energy Savings mode, the set point will be reduced by 20°F (11°C), which means that the heating system will not be engaged unless the temperature falls to 20°F (11°C) below the spa's set temperature.

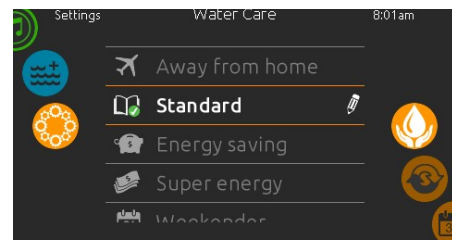

Water Care Modes:

Away:

In this mode the spa will always be in economy; the set point will be reduced by 20°F (11°C) and the filtration can be reduced.

Beginner:

The spa will never be in economy mode, and will run a normal 24 hours of filtration a day.

Energy Savings:

The spa will be in economy mode during the peak hours of the day and resume normal mode on the weekend.

Super Energy Savings:

The spa will always be in economy mode during peak hours, every day of the week.

Weekender:

The spa will be in economy mode from Monday to Friday, and will run normally on the weekend.

MODIFYING SCHEDULES

To see and / or modify the Water Care category, use the Settings icon to open the selected Water Care menu.

Scroll through the menu to choose a schedule to modify (choice of economy and filtration schedules).

You have several possibilities for the schedule (Mon-Fri, weekend, every day, or single days). The schedules will be repeated every week. The time and duration are set in 30 minute increments. Once you have set the schedule, use Spa Function Icon to go back. Ensure that you have selected the desired Water Care option in the main Water Care menu.

The filtration schedule shown on the screen will apply to the main filtration pump. Your spa uses a circulation pump configured to run 24 hours by default and the screen will show you the purge setting instead of filtration. The purges are pre-programmed for a fixed number of minutes, therefore the duration will be set to N/A on the screen, and only the start time can be modified.

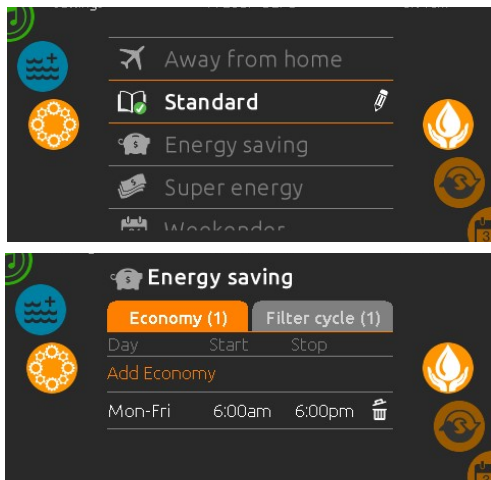

FILTERING

Your spa is equipped with a circulation pump that filters your water for 24 hours a day. If the water temperature exceeds the set temperature by 4°F (and set point is 95°F or higher) then this pump will shut off automatically until the temperature drops below the set point by approximately 1.5°F.

You can bypass the pack filtration over-temperature feature. When Warm weather is "Off", the filtration over-temperature is disabled. This feature allows the spa to continue filtering even through the water temperature is high.

MAINTENANCE

From the Settings page you can access the Maintenance Menu, which gives you access to the following options:

- Maintenance reminders
- Standby

Press the text to make a selection.

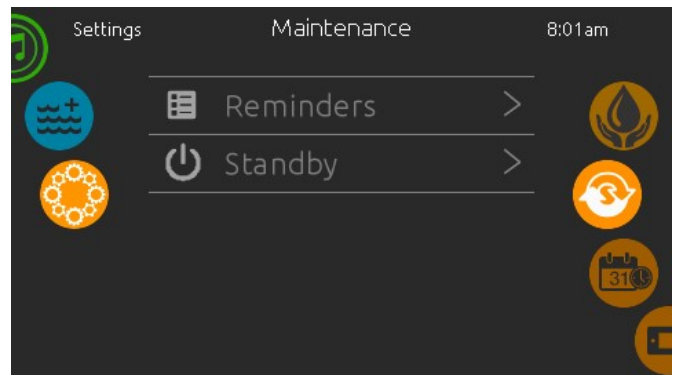

MAINTENANCE REMINDERS

The in.k1000 keypad will remind you of maintenance required on your spa, like rinsing or cleaning the filter. Each task has its own duration, based on normal use.

The Maintenance Reminders menu allows you to verify the time left before maintenance is required, as well as to reset the time once a task is completed.

Scroll through the menu to move through the list.

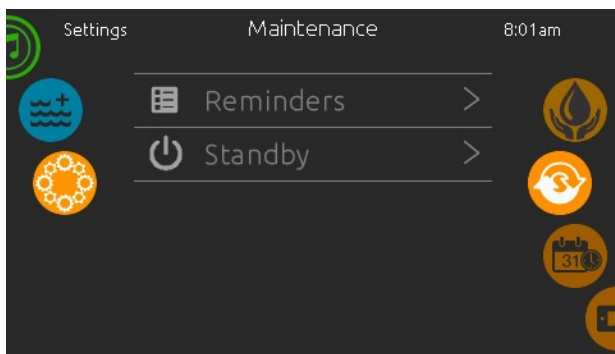

STANDBY

The Standby mode allows you to service your spa. Pumps will stop for 30 minutes, and automatically restart after this time.

Once Standby mode has been activated a screen will appear to show the pumps are stopped. The normal spa page will return at the end of the maintenance.

Press Cancel to leave Standby mode and restart the spa.

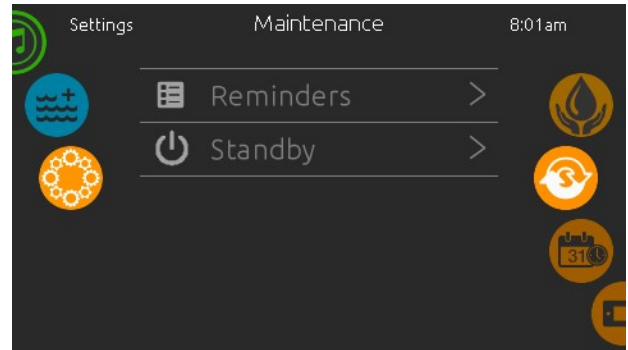

DATE AND TIME

Here you can adjust the time format (AM/PM or 24h), day of the week and time. Use the icons to choose the setting that you want to adjust and select it by scrolling through the menu.

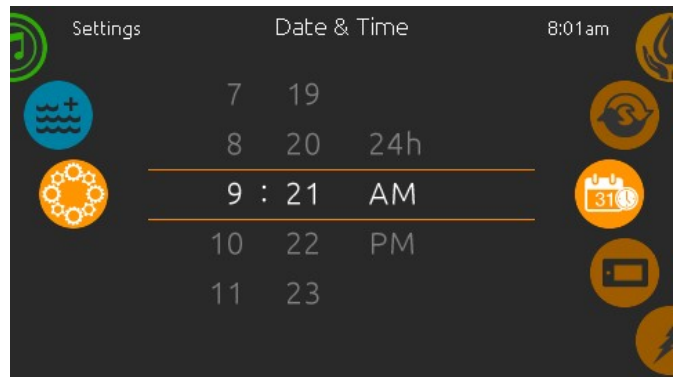
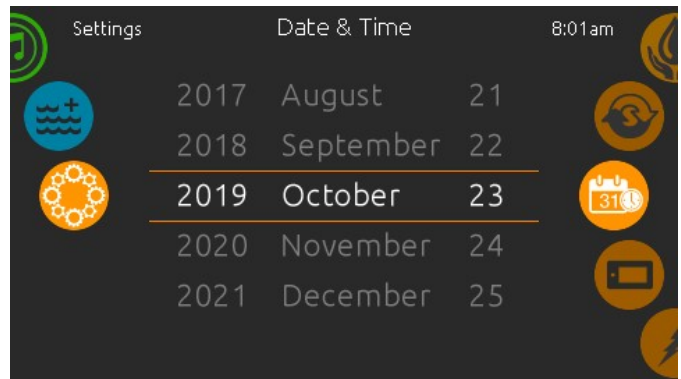

KEYPAD SETTINGS

In this section you can change the temperature unit and language. Use the arrow keys and move to the setting that you would like to change. Use the Light key to choose and the arrow keys to modify

For the temperature setting you have a choice between Fahrenheit or Celsius.

For the language setting you have a choice between English and French.

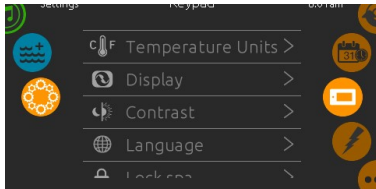

ELECTRICAL CONFIGURATION

Please do not make changes in this section unless you are a qualified electrician.

ABOUT

This section shows information about the keypad software number and the revision numbers of the different components of your system.

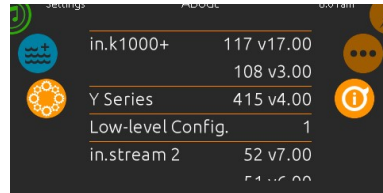

PURGE CYCLES

The purge cycles are programmed to begin at the start of each filter cycle. Pump 2 activates for 1 minute, shuts off and then Pump 1 activates for 1 minute then shuts off.

SMART WINTER MODE

Smart Winter Mode protects your system from the cold by turning the pumps on several times a day to prevent water from freezing in the pipes. The Smart Winter Mode indicator turns on when in this mode of operation. If the temperature drops to 4°C (39°F) within the heater chamber, the system automatically activates the pump to provide freeze protection. The pump will operate until the temperature reaches 5°C (41°F) before returning to normal system mode.

COOLING DOWN

After heating the spa water to the desired set point, the heater is turned off, but the filtration pump remains on for a certain amount of time to ensure adequate cooling of the heating element in order to prolong the useful life of the heater.

OPTIONAL SWIM SYNC SYSTEM

The Smart Phone App that is designed as a wireless hot tub control which allows you to pick the water care settings that fit your schedule. Adjust filtration and temperature settings and create the ideal hot tub experience from inside your home. This option is supported by your iPhone®, iPod touch®, iPad® (requires iOS 8.0 or later) and Android Device (requires Android 2.3.3 and up).

In. touch 2 comes with a state-of-the-art app and 2 pre-paired radio frequency transmitters: One being part of the spa system and the second one, being connected to the Home Internet router. Both RF transmitters are pre-linked to one another, enabling an immediate and perfect communication between user and the spa.

1. Installing the home transmitter

The home transmitter is provided with an Ethernet cable and a power supply. The in. touch 2 home transmitter unit must be installed inside the house, connected to a router and powered by the provided wall transformer. A longer Ethernet cable may be used to bring the home transmitter closer to the spa.

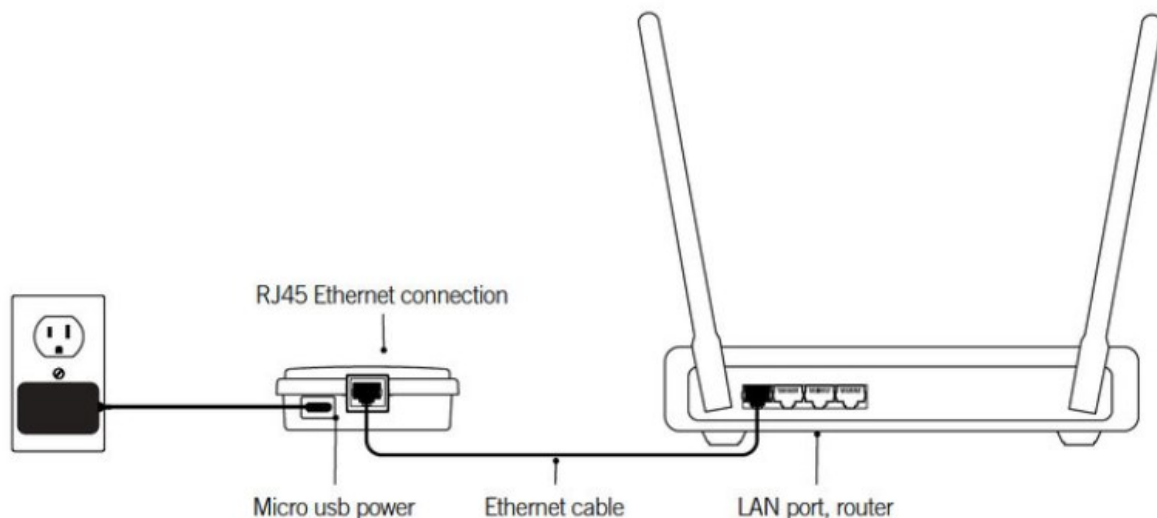

Simply connect the Ethernet cable into the RJ45 port of the in. touch 2 home transmitter and in one of the available LAN ports on your router. To power up the home transmitter, plug the provided wall outlet charger to a 120V (North American model) or 220V (European model) household supply and connect the USB cable to the wall outlet and the home transmitter.

2. Installing the spa transmitter

If you purchased a spa with in. touch 2 as a standard feature or as an option, note that the spa transmitter will be pre-installed.

To ensure proper signal transmission, it may be necessary to change the position of the transmitter once the spa is installed in the yard. The transmitter should be located on the side of the spa facing the house.

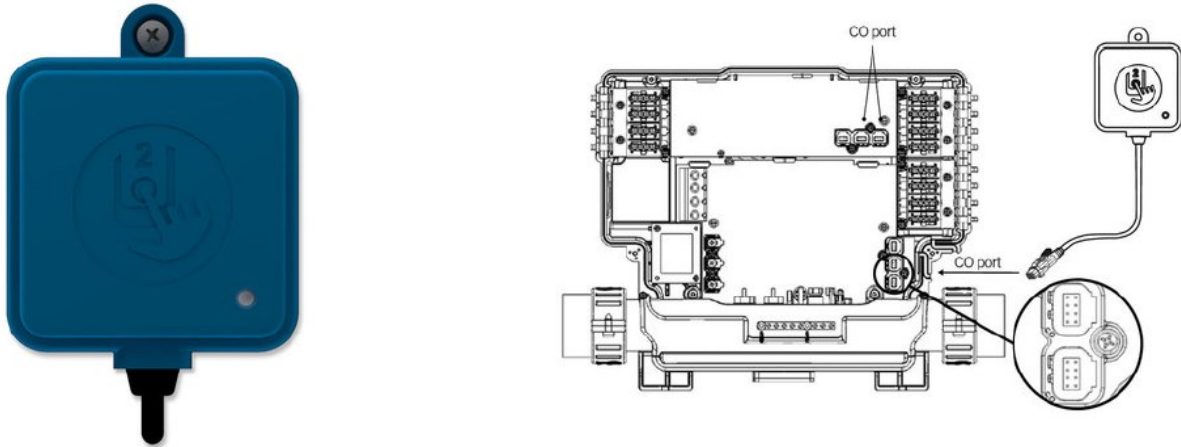

The in. touch 2 spa transmitter must be installed under the spa skirt, at least 12" (30 cm) away from any metal component or structure, as close as possible to the house to optimize the signal strength.

Simply connect the spa transmitter into an available CO port of the spa control system (or any other accessory with a free CO port, such as the in. stream 2 audio amplifier, or the in. clear water sanitization system).

3. Pairing the home and spa transmitters

If you bought an in. touch 2 equipped spa or a complete retrofit kit, both transmitters of your in. touch 2 will be factory pre-paired.

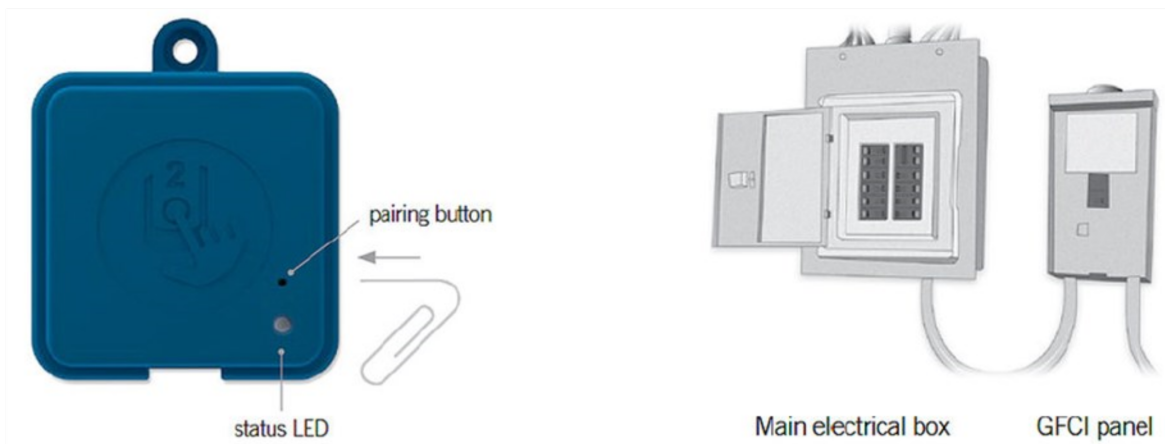

If you need to replace a transmitter or pair your transmitters again, power up the home transmitter and press on its pairing button with a paper clip. The status light of the transmitter will blink yellow.

Then, shut off the spa’s breaker to turn the spa transmitter off. Wait a little and put the breaker back on. Within a few seconds, pairing will be completed and both transmitter status lights will turn to blue.

4. Transmitters status LED indicator

Both the home and spa transmitters have color status LED that can be used for troubleshooting purposes

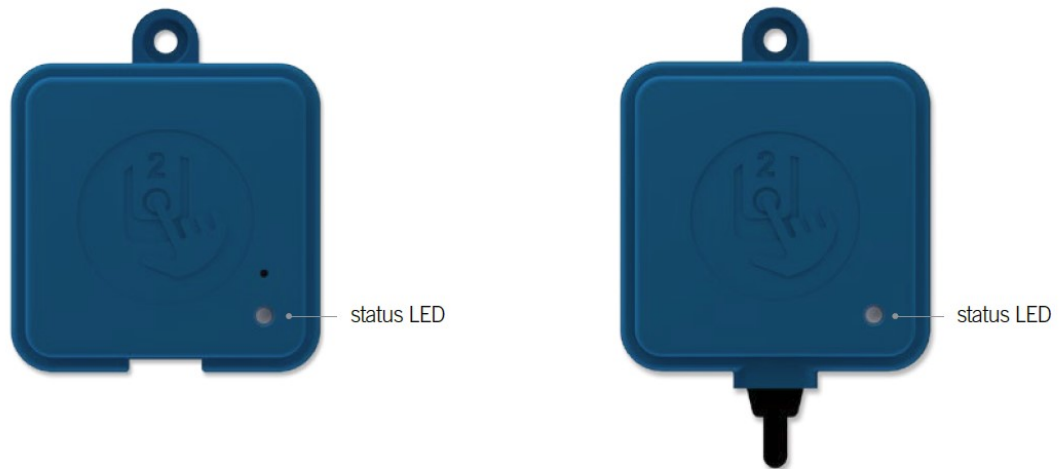

Home Transmitter

Pairing mode	Yellow (Blinking)
Router not detected	Red
Router detected	Green
in.touch 2 server detected	Blue
Module is fully functional	Blue

Spa Transmitter

Pairing mode	Yellow (Blinking)
Spa controller not detected	Red
in.touch 2 server detected	Blue
Module is fully functional	Blue

When the LED status is blinking (blue, green or red) this indicates that the communication between the EN module and the CO module it not established.

5. Strong and Long Range Communication Signal

Through their proprietary RF technology, in. touch 2 transmitters emit a strong, stable and long-range signal between your spa and your router (about 3 times longer than regular signal). No need for repeaters or boosters: your spa will always remain within reach in typical backyard settings.

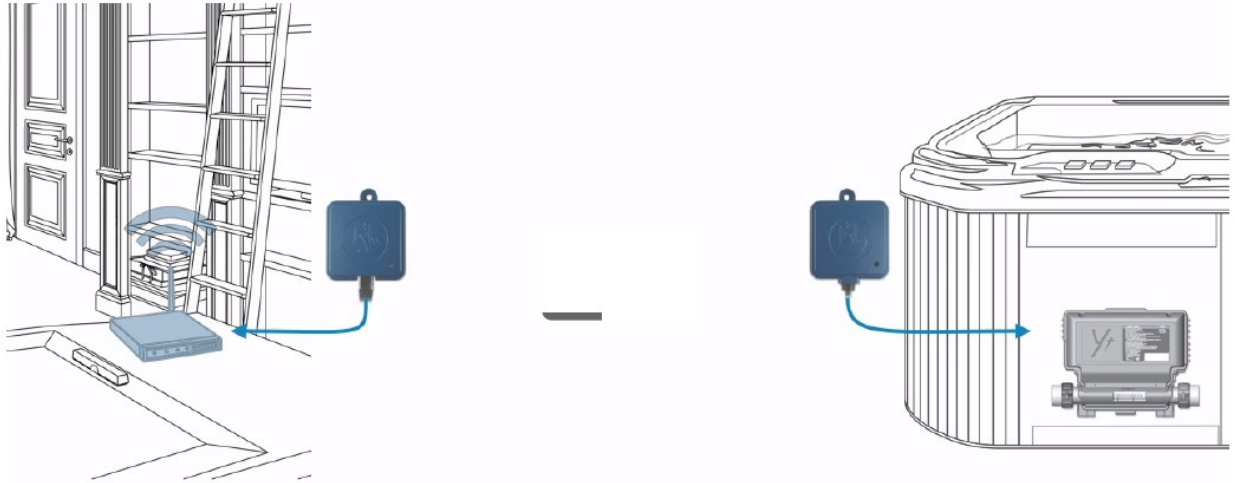

6. Application

Download application:



The in. touch app allows you to control your spa using your home network or an Internet connection anywhere in the world. The in. touch 2 app is waiting for you in the App Store for iOS devices and on Google Play for Android — search for « in. touch 2 » then click on it to install.

USING THE APP

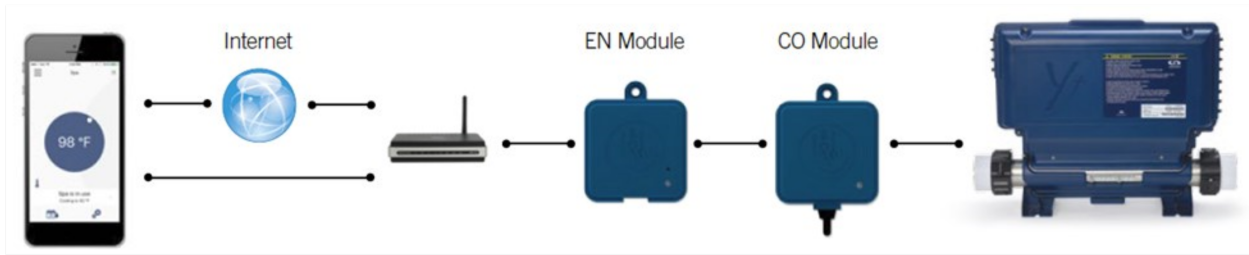

On your home network

It is possible to access your spa with the in. touch 2 app through your home network. To be able to see your in. touch 2 in the application you need to connect your device to the same router (Wi-Fi network) than the one used to connect your Home Transmitter. Go to the Wi-Fi settings section of your mobile device and choose the same network that your spa is connected to (i.e. Home). Once you've selected it, wait until your device confirms the connection.

On the Internet

The in. touch 2 allows you to use the Internet to control your spa from anywhere in the world. In order for them to communicate, both the in. touch 2 module and your device must be connected to a network that allows access to the Internet. Once your Home Transmitter is connected to the Internet (the LED status is blue), you can use your in. touch 2 app any time your device is also connected to the Internet (wireless or cellular network), even if you are away from home. To have access to your spa away from home, you will need to have previously linked your mobile device to your spa on your home network.

Setup your Wi-Fi on your device

Before using your application, go to the Wi-Fi section of your device's settings. Make sure you are connected to your home network. This needs to be the same Wi-Fi provided by the router to which you connected your Home Transmitter.

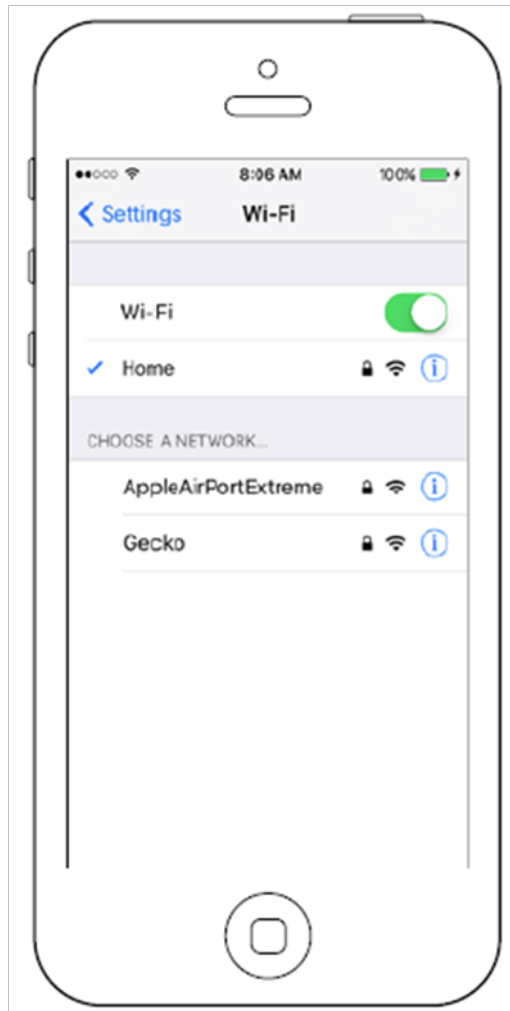



Find the icon for the in. touch 2 application, then tap on it to open it.

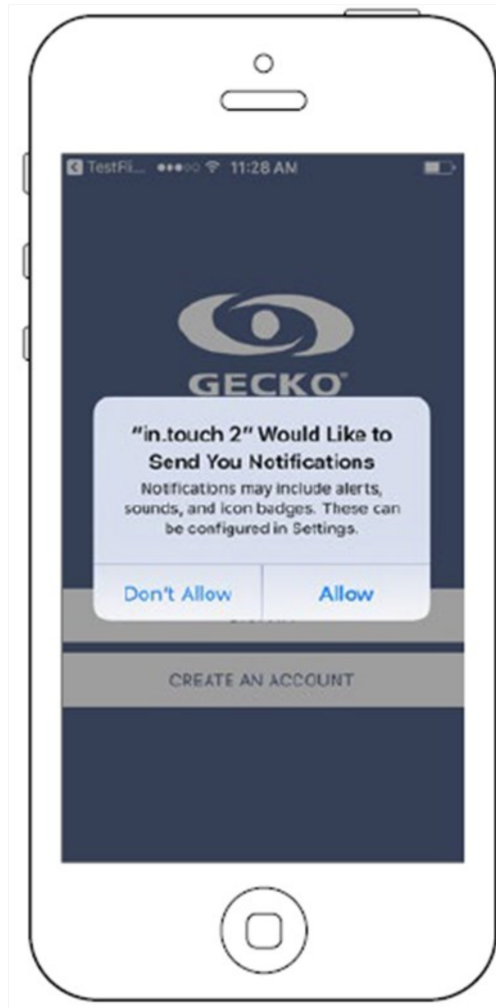

The first time you use the application a message will ask you: "in. touch 2" Would like to send you notifications. If you choose *Allow*, the application will send you notifications about the status of your spa. If you choose *Don't Allow*, the application will not send you notifications.

Login page

Before using your application, you must create an account first and then, you'll be able to sign in. Your account will give you the opportunity to have access to your spa from any in. touch 2 application.



New account creation

When you choose to create a new account, you agree at the same time the Terms of Service and the Privacy Policy. You can read them at any time through this link:

<https://geckointouch.com/legal>

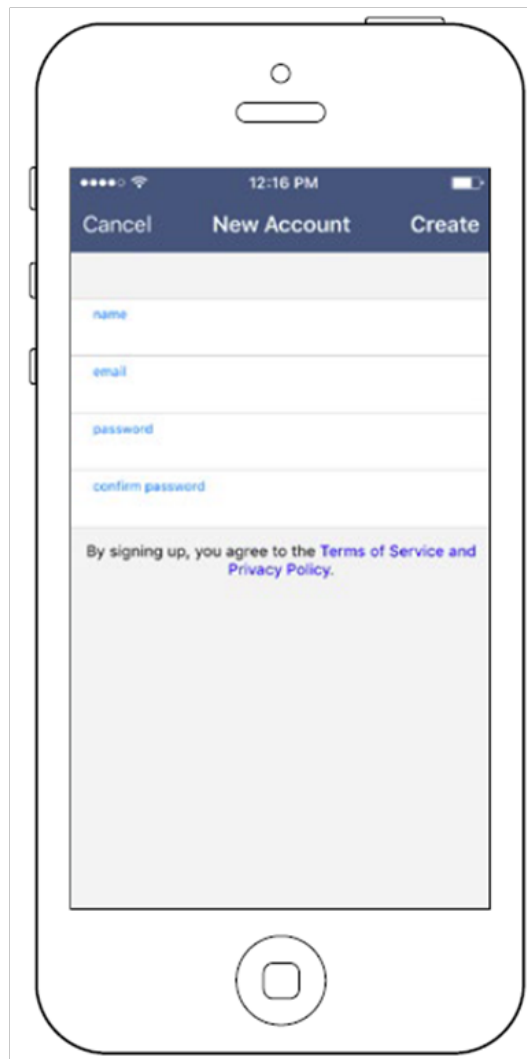

The image shows a mobile application interface for creating a new account. The screen is titled "New Account" and features a dark blue header with "Cancel" on the left and "Create" on the right. The main content area contains four input fields: "name", "email", "password", and "confirm password". Below these fields is a disclaimer: "By signing up, you agree to the Terms of Service and Privacy Policy." The status bar at the top indicates the time is 12:16 PM. The interface is presented within a white border that mimics the shape of an iPhone.

Choose a spa



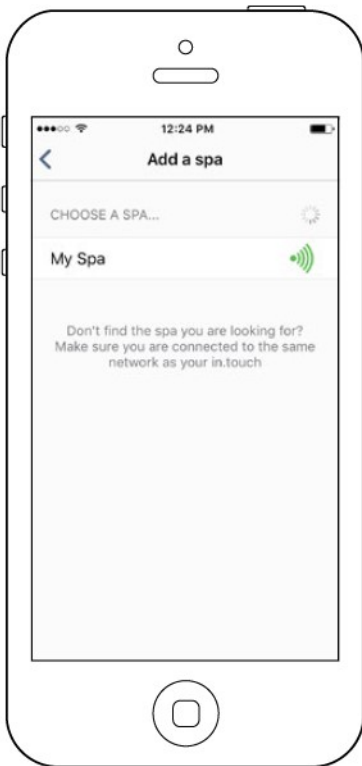

This page displays all the spas detected by your application.
To detect your spa, you need to connect your mobile device to the same network to which you connected your Home Transmitter.

Once you have done a connection with the spa its name will be saved on this page to allow you to connect to this spa from anywhere.

To add a spa later on, go to Settings (up right corner) - Add a spa



The RF signal strength (communication between the two in.touch 2 transmitters) is illustrated on the Select a spa page. There are 5 possible states:

-  • Signal superior to 80%
-  • Signal between 80% and 51%
-  • Signal between 50% and 31%
-  • Signal below 30%
-  • The Spa Transmitter is not available

Home page

The main screen gives you access to your accessories, water temperature, water care and settings.

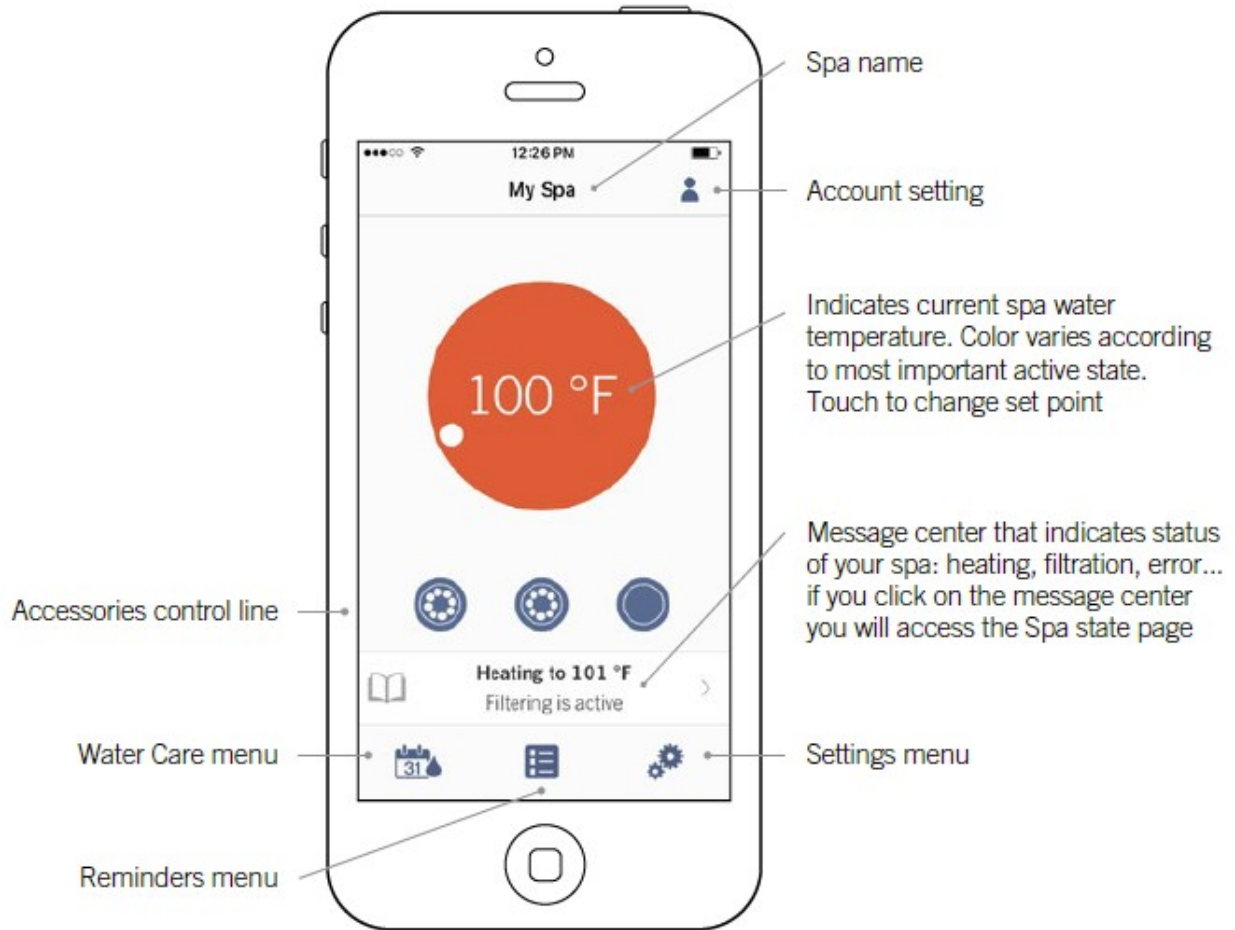

The app is mirroring the top side control (keypad) over the internet.

STANDBY MODE



A press of the **SETTINGS** icon and scroll to the **MAINTENANCE** menu options. Press the **MAINTENANCE** icon to display the **STANDBY** icon. Press the **STANDBY** icon and the following message will appear.

“All pumps off! Press Cancel to exit Standby mode or Drain to drain spa”

This mode allows you to stop all outputs including all automatic functions such as a filter cycle, heating requests and smart winter mode purging for 30 minutes to perform quick spa maintenance.

DRAIN MODE

If you wish to put your spa into **“DRAIN MODE”** follow the instructions above for putting the spa into **“STANDBY MODE”** and then press **DRAIN** on the display. Once you do that the display will indicate **“Drain in progress”**. The filtration pump will turn on and run for 60 minutes.

TOPSIDE PANEL DISPLAY MESSAGES

Hr - An internal hardware error has been detected

Prr - The Prr error message indicates a problem with the regulation probe. The system is constantly verifying if the temperature probe reading is within its normal limits.

HL - The water temperature at the heater has reached 119°F (48°C). **Do not enter spa water.**

FLO - The system did not detect any water flow while the filtration pump was running.

UPL - No low level configuration software has been downloaded into the system.

AOH - The temperature inside the spa skirt is too high, causing the internal temperature in the spa pack to increase above the normal limits.

OH - The water temperature in the spa has reached 108°F (42°C). **Do not enter spa water.**

SWIMFALL WATERFALL CONTROL FILTER

This filter must be cleaned at each drain and refill of your swim spa to ensure proper functionality of the Swimfall Waterfalls. It is located behind the door in the equipment area. To access the filter screen turn large canister section of the assembly counter-clockwise till the apparatus separates revealing screen filter. Run filter under tap to clean out any debris and reassemble in reverse order.

NOTE: When winterizing your swim spa, the canister section must be disassembled so that all the water can be vacuumed out properly to prevent damage from freezing conditions before it is reassembled for winter storage.



ADJUSTABLE FLOW CONTROL

Your Swimlife swim spa is equipped with a DIVERTER valve to control and adjust water flow to suit individual user preference. The pump 1 (P1) DIVERTER valve provides variable water flow adjustment between the lower centre swim jet (providing added buoyancy and variable swim resistance), and the hydrotherapy jets on the bucket seats, or a combination of both.



WAVE RIDER CURRENT CONTROL (SWIM EXPERT MODELS only)

This system allows for the swimmer to vary the flow of water and adjust the swim intensity of the jets. Allows quick adjustment to level of fitness the swimmer is accustomed to from Novice to Triathlete. This option has keypads near the swim end so that they can easily adjust their swim without having to go back to the main keypad area and eliminates the need for manual diverters.

NOTE: You should always start from a full on or full off position to ensure you have consistent water flow. Failure to do so may unbalance the system requiring it to be recalibrated.

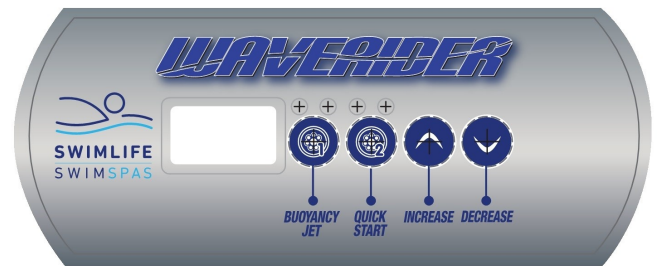

WAVE RIDER SELF-CALIBRATION PROCEDURE

1. Activate pump 2 and 3 from the main keypad.
2. Press and hold the Quick Start key on your Waverider keypad for 30 seconds (until the screen shows "60.H" for North American product and "50.H" for European product).
3. Then release the key and press it one more time. The display will show "SE.1", press the Quick Start key one more time, the display will show "SE.2", press it again and the display will show "LEA" (learning mode).
4. At this time the actuator valve that controls the water flow to the swim jet will get activated all the way to maximum speed and then all the way down to the minimum speed.
5. Once it's done, the keypad should show "0". If you have an "Err" code, there is a defective actuator.
6. To find out which one is defective, just compare the pressure coming out of the jet and replace the one that is more powerful.

To prevent the system from losing it's calibration, always wait for the actuator to reach the speed that you have selected before pressing the arrow up or down again. Just wait for the selected # to be solid on the screen before pressing the arrow up or down button again.

Contact your local retailer for service.

WAVERIDER CONTROLS

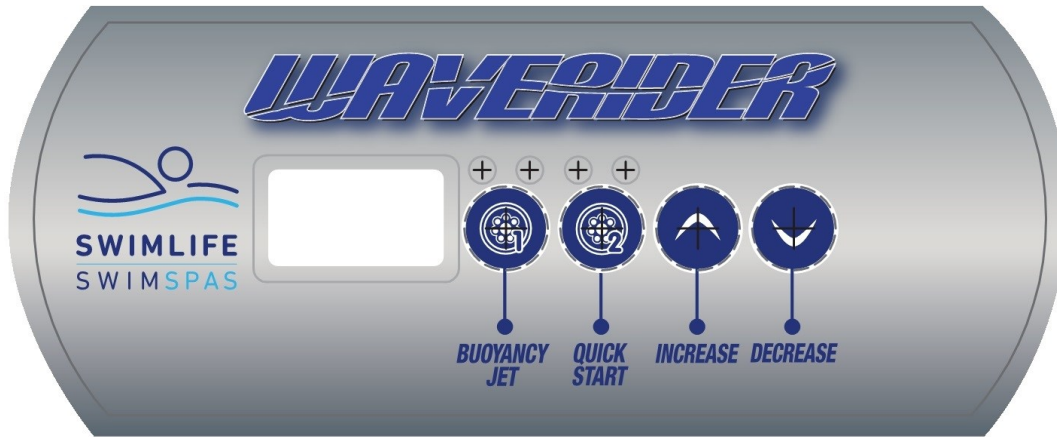

KEYPAD FUNCTIONS AND DISPLAY ICONS



PUMP 1 FUNCTION KEY
TURNS ON BUOYANCY JET



INCREASE FUNCTION KEY
INCREASES SPEED



PUMP 2 & 3 FUNCTION KEY
TURNS ON SWIM JETS



DECREASE FUNCTION KEY
DECREASES SPEED

OTHER DISPLAY FUNCTIONS

When the WAVERIDER system is operating the display will scroll between calories, distance and time in order to give you feedback on the results of your swim.

SWIMLIFE CLEARSTREAM MINERAL SYSTEM

KEYPAD FUNCTIONS

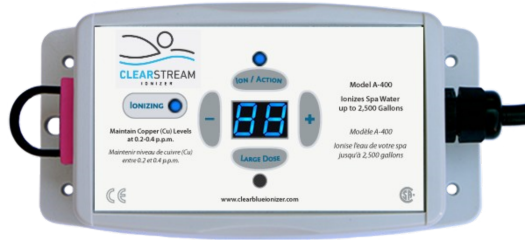

IONIZING - When the “Ionizing” light is illuminating, it confirms that everything is hooked up correctly and the system is releasing minerals into the water. The “Ionizing” light will flash when the mode is set to Large Dose *If no lights are illuminated, please confirm the power is connected. Contact your dealer if necessary for assistance.

ION/ACTION - This factory pre-set setting represents the percentage of time in each hour the ionizer is on for. The suggested setting follows in the operating instructions.

LARGE DOSE - Press this button to release the maximum amount of ions for the number of hours you choose. The display will count down the amount of hours left. The system will return to the previously set Ion/Action setting when the large dose ends. Use this function at your discretion whenever a burst of ions is required. You may choose to use this when the ionizer is first installed, upon refilling or during large amounts of rain or spillage.

“-” This button will decrease the setting for Ion/Action or Large Dose.

“+” This button will increase the setting for Ion/Action or Large Dose.

PROGRAM LOCK This feature will lock the controller at the currently programmed settings. To lock the program, hold the “-” button and the “+” button simultaneously for 20 seconds, you will see “PL” (program lock) appear on the screen. To unlock, use the same process

* Note: Large does will not work if Program Lock is turned on.*

CLEAR STREAM STARTUP INSTRUCTIONS

Fill the Swim Spa. If filling from a garden hose, a Pre-Filter must be installed on the garden hose to eliminate excess minerals from the water source.

After your Swim Spa has been powered on, test & balance your water. Recommended levels can be found on page 37.

Press the Indicator light button on the exterior of the Swim Spa to initiate the large dose mode. The light will begin to flash. Test your copper level after 7 days the level should be 0.2 –0.4 ppm. Repeat this step every 7 days until the copper level is within the recommended range. See your local retailer for further guidance if required.

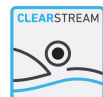

CLEARSTREAM OPERATING INSTRUCTIONS

PROGRAM - Press the “Ion/Action” button to set the ion cycle time. Follow the guidelines below based on the gallons or liters you are ionizing.

OPTIONAL - Press the “Large Dose” button to set the hours of large dose. You may set it from 1 to 99 hours. 24 hours will activate as the default setting. Follow the guidelines below. When the large dose cycle is finished it will return to the previously set Ion/Action setting.

MODEL	LITERS	GALLONS	ION/ACTION	LARGE DOSE
SWIMFUN	4670	1229	43	46
SWIMSTREAM	7220	1900	67	71
AQUASTREAM	9120	2400	86	91
DUALSTREAM (SWIM END)	6692	1761	63	65
DUALSTREAM (SPA END)	1197	315	11	12

Please note these are factory set. You may need to further adjust the levels based on your copper test kit readings. Based on the mineral output, it will take approximately 7 days to attain the minimum copper residual of 0.2ppm and 14 days to attain the copper residual of 0.4ppm in the maximum Swim Spa volume stated on the label. Your Swim Spa will be safe to enjoy during this time provided your water is balanced and has a chlorine level in the 2-4ppm range. Once your copper levels are with in range you may reduce your chlorine to a 0.5-1ppm range.

CLEARSTREAM MAINTENANCE INSTRUCTIONS

- 1) **Copper Test:** Using the included copper test strips, ensure ions are between 0.2 - 0.4 ppm; spa applications can increase copper level up to 0.6ppm. Test the copper level once a week until you have found the proper Ion/Action setting for your pool or spa. Increase or decrease the Ion/Action setting as required. Carefully read and follow the instructions for your copper test kit. Check the expiration date of the copper test kit as test results may be inaccurate if used after that date.
- 2) **Mineral Cell:** The mineral cell that delivers minerals to the water needs to be checked every 6 months and typically lasts for 12-18 months. You can purchase additional cells from your authorized dealer. To replace the cell, simply turn the old cell counter-clockwise to release it from the tee. Wrap the new electrode with Teflon Tape and use your hand to turn the new cell clockwise into the tee until it is secure. If possible, turn until the electrode bars sit parallel to the water flow (so water flows between them).
- 3) **Oxidize The Water:** Occasionally, you will need to oxidize the water to help break down excess organic matter (i.e. sweat, urine, makeup, suntan oils). In pools, we suggest running your ionizer system in conjunction with 0.6 ppm chlorine or bromine. Chlorine tablets are recommended before liquid shock as they are extremely stable and slow releasing. Or, you may prefer a non-chlorine oxidizer which is pH neutral.

CLEARSTREAM MAINTENANCE INSTRUCTIONS CONT'D

- 4) **Keep the total alkalinity between 80 and 120 ppm.**
- 5) **Keep pH between 7.2 -7.6.** Unlike chlorine, ions are pH neutral so they will not change the pH level of the water. But your choice of oxidizer or environmental factors may.
- 6) **Keep calcium hardness between 200 and 300 ppm.**
- 7) **Keep total dissolved solids (TDS) between 500 and 2,000 ppm.**
- 8) Ensure **phosphates** are at 100ppb or less by testing phosphates on an algae free Swim Spa (chlorine must be below 5ppm). If phosphates are above 100ppb use PHOSfree or similar product to remove the bulk of the phosphates. Once the phosphates are below 100ppb, maintain with Pool Perfect+PHOSfree or similar. If phosphate levels continue to rise, the following may be the cause: fertilizers, organics, metal sequestering products, scale products, or extreme rainfall. The above will cause phosphates to continue to rise above what Pool Perfect+PHOSfree can maintain. It is important to reduce/eliminate the source of the phosphates for Pool Perfect+PHOSfree to work properly. If possible, prevent runoff from gardens and lawns from entering the pool. Remove leaves from the pool regularly and promptly.
- 9) You may need to add a **clarifier** if you see cloudy water or fine particles in the water which the filter cannot catch. With the pump turned off, the clarifier clumps fine particles together and causes them sink to the bottom. When the particles have settled on the bottom of the Swim Spa they are easily removed by vacuuming. This is not a dangerous chemical and it is used in small quantities. Please follow the directions on the product label.
- 10) **Note: 'Stain and Scale'** or other sequestering products conflict with ClearStream. If you use a stain and scale or other sequestering product, it will remove the ClearStream minerals from the water and neutralize new minerals for several weeks. Before adding a sequestering product, turn off the ClearStream controller by unplugging it from the power source, or turning down the 'Ion/Action' setting to 00 to preserve the life of the electrodes. After three to five weeks, you can turn the controller back on. You will need to ramp up the copper level to 0.2ppm to 0.4ppm again using the method described above. If you have a serious staining and scaling problem, it can also be treated at the point where the water enters the pool or spa using a metal trap filter. This filter can be attached to the garden hose and will provide better water quality for your Swim Spa.

CLEARSTREAM CLEANING & CARE INSTRUCTIONS

- 1) Mineral Cell Electrodes: Some deposits may form on the electrodes depending on the water conditions. Clean the flat face of the electrodes using a smooth metal file and some water. The surface does not have to be polished; simply remove any traces of oxidization and other sediments.
- 2) System Exterior Controller Panel: Care should be taken in cleaning the controller panel. If the panel becomes soiled, wipe it with a cloth dampened slightly with water only. Dry with a soft cloth. Do not scrub or use any sort of chemical cleaners.

CLEARSTREAM CELL REPLACEMENT

The ClearStream mineral cell will last 12-18 months, depending on the size and usage of the Swim Spa. The larger the Swim Spa, the quicker the cell will wear down.

The first cell will go faster because the minerals need to ramp up in the water. After you have reached the recommended level of 0.2ppm – 0.4ppm copper ions, the minerals are very stable in the water.

The ClearStream cell is installed in a clear tee in the plumbing. You can look through the tee to see if there is any material left on the two mineral plates, and should be inspected at 12 months and then every 3 months thereafter until the cell is replaced.

If you cannot see through the tee, there is a light labeled 'Ionizing' on the left side of the controller, and a light on the indicator on the cabinet. As long as this light is flashing, there is life in the cell.



Here is a picture of a cell that is ready to replace:



AUXILIARY HEATER BYPASS LOOP

When your installation calls for an auxiliary heater, our swim spas can be built with special plumbing that will easily and reliably allow for the additional installation of an alternative heat source (heat pump, electric heat, gas heat or solar). Simply connect your additional system plumbing to our pre-installed plumbing and check valve system for optimal performance and safety.



SWIM SPA WATER BALANCE – GENERAL OVERVIEW

NOTABLE POINTS

- The reliability and longevity of your swim spa support equipment are directly related to how well water quality is maintained!
- The small volume of water in your swim spa is easily affected by the introduction of oils, lotions, perspiration and chemicals. It is imperative that you give your swim spa regular attention to maintain clean, safe and balanced water to prevent premature damage and/or failure (corrosion/calcification) to the support equipment. Maintaining proper swim spa water balance and sanitizer levels is extremely important. Neglected hot water will allow bacteria to quickly spread.
- The mineral content of swim spa water increases due to water evaporation, sanitizers and other chemicals. If the mineral concentration, particularly calcium, becomes too high, the minerals will literally “drop” or precipitate out of the water and deposit on the swim spa walls, plumbing, jets, in the filter and on the heater element.
- It is very important that pH be checked frequently and maintained in the recommended range as indicated in the chart **WATER BALANCE SUMMARY FOR YOUR SWIM SPA**
- It is also very important that Total Alkalinity (the ability of the water to resist a change in pH) be maintained in the recommended range as indicated in the chart **WATER BALANCE SUMMARY FOR YOUR SWIM SPA**
- Although there may be two identical swim spa models right next door to each other, the maintenance requirements will be different, dependent on such factors as:
 - bather load
 - frequency of use/quantity of bathers
 - different body chemistry
 - sun vs. shade
 - temperature

For these reasons, it is very important to develop proper swim spa water maintenance habits and follow your Swimlife retailer’s recommended water maintenance procedures.

Floating dispenser: Add 6 or 7 tablets, adjust initially to ‘5’, allow water to circulate for 3 to 4 hours, then test.

The tablets will dissolve slowly over a 10-14 day period, depending on setting, and use of the hot tub.

5 Test pH and Total Alkalinity and also adjust accordingly.

Expose the large Refill hole at the end of the tube and add 5 or 6 tablets.

Do not overfill dispenser as performance will be affected. Turn to

expose the largest area and allow water to circulate for 3 to 4 hours before testing level. Adjust to lesser area as necessary to maintain a level of **3-5** PPM Sanitizer.



WARNING

CHEMICAL HANDLING SAFETY HINTS

- **Never pre-mix chemicals with each other prior to adding to hot tub water.**
- **Add only one chemical to the water at a time.**
- **Always add chemicals to water and not vice-versa.**
- **Chemicals may be corrosive, so handle with care and store in a cool dark place.**
- **Never smoke near chemicals as most are flammable**
- **Ensure any spilled chemicals are carefully cleaned up immediately.**
- **Always have the POISON CONTROL telephone number handy in the event of an emergency.**
- **Keep chemicals out of children’s reach**
- **Wear safety glasses and gloves when handling chemicals.**

INITIAL WATER FILL & BALANCE

- 1 Make sure the swim spa is circulating.
- 2 Add a sequesterant (stain and scale controller). Allow water to circulate for an hour before adding anything else to the swim spa water.
- 3 Add a Shock / oxidizing agent.
- 4 Add sanitizing tablets (Bromine or Chlorine) to the dispenser.



Heater and other component failure due to improper water balance is not covered under warranty.

GLOSSARY OF COMMON WATER MAINTENANCE TERMS

1. **CHLORINE** – in granular, liquid or puck/tablet form, is an oxidant and biocidal agent. It is very effective and fast acting. Recommended chlorine residual level is 3.0 to 5.0 ppm.
2. **CHLORAMINES** – a compound formed when chlorine combines with nitrogen or ammonia present in the water. When allowed to go unchecked, it causes eye and skin irritation and is indicated by a strong chlorine odor.
3. **ONE-PART BROMINE** – also available in puck/tablet form, is another type of oxidant/biocidal agent, and is introduced into the hot tub water via a brominator. Recommended bromine residual level is 3.0 to 5.0 ppm.
4. **TWO-PART BROMINE** – composed of a liquid or powder component introduced manually into the water on a weekly basis, and a granular component that is added daily or as the hot tub is used.
5. **BROMAMINES** – are formed when bromine destroys nitrogen-bearing organic matter. Unlike chloramines, bromamines don't cause eye irritation, however, when allowed to go unchecked, will cause an objectionable odour.
6. **SHOCK** – the practice of adding an oxidizing agent to hot tub water to destroy ammonia, nitrogenous and organic contaminants (chloramines and bromamines)
7. **pH** – a logarithmic value expressing the relative acidity or basicity of a substance (such as hot tub water) as indicated by the hydrogen ion concentration. pH is expressed as a number on a scale of 0 to 14, where 0 is most acidic, 1 to 7 being acidic, 7 considered neutral, 7 to 14 being basic, and 14 being most basic. The ideal range for hot tub water is 7.4 to 7.6 ppm
8. **pH INCREASER** – raises the pH level of the water.
9. **pH DECREASER** – lowers the pH level of the water.
10. **TOTAL ALKALINITY (TA)** – the amount of carbonate, bicarbonate and hydroxide compounds present in the water that determines the ability or capacity of the water to resist change in pH. Also known as the 'buffering' capacity.
11. **ALKALINITY BOOSTER** – raises the alkalinity.
12. **CALCIUM HARDNESS** – the calcium portion of the total alkalinity which represents 70 to 75% of total hardness. Calcium concentrations determine whether water is 'soft' - too little calcium, or 'hard' -too much calcium.
13. **CALCIUM BOOSTER** – increases the calcium level.
14. **TOTAL DISSOLVED SOLIDS (TDS)** – a measure of the total amount of dissolved matter in the water (calcium, carbonates, bicarbonates, magnesium, metallic compounds, etc.)
15. **SEQUESTERANTS (STAIN AND SCALE CONTROLLERS)** – keeps dissolved metals and minerals in the water from attacking the hot tub shell and support equipment components.
16. **DEFOAMER** – removes foam build-up from the water surface. At best, this is a temporary remedy, as excessive foam is merely a symptom of improper water balance (typically high organic residue and/or high pH).
17. **CARTRIDGE FILTER CLEANER** – degreases and cleans cartridge filters.
18. **OZONATOR** – generates Ozone (a gaseous molecule composed of 3 atoms of oxygen) and is injected into the hot tub water for the oxidation of water contaminants.
19. **TEST KIT** – used to monitor specific chemical residual or demands in the water. May be in the form of litmus strips or liquid drops.
20. **20 PPM** – abbreviation for 'parts per million', the unit of measurement used in chemical testing which indicates the parts by weight in relation to one million parts by weight of water. Essentially identical to the term mg/L - milligrams per liter.

WATER BALANCE SUMMARY FOR YOUR SWIM SPA*

SANITIZER (ppm)	MIN	IDEAL	MAX
Chlorine	1.0	3.0 - 5.0	5.0
Bromine	1.0	3.0 - 5.0	5.0
CHEMICAL			
PH	7.2	7.4 - 7.6	7.8
Total Alkalinity (TA)	80	80 - 120	180
Calcium Hardness	150	200 -400	500 -1000

*National Spa & Pool Institute recommended levels for residential spas/hot tubs

WATER BALANCE TROUBLESHOOTING

PROBLEM	POSSIBLE CAUSES	SOLUTIONS
Cloudy Water	Microscopic particles too small to filter out.	Test and adjust all water balance elements and add flocculent* to cause the particles to combine together so they can be filtered out. Increase filter cycle time.
High Total Alkalinity High pH levels High Calcium Hardness		Test these water balance elements and adjust to recommended parameters.
Scale (White/Grayish Deposit)	High Calcium Hardness	Test calcium hardness level and treat with sequestering agent* or perform partial drain/refill.
Skin Eye Irritation	Improper pH and/or Total Alkalinity levels	Test water balance and make the appropriate changes.
Excessive Foam	Buildup of body oils or cosmetics	If no water line is present you can try using defoamer* to break up the contaminants and then a clarifier* to help filter them away. If a water line is present the spa may need to be drained and cleaned. Either way, the filter should be thoroughly cleaned by soaking overnight in bleach. An oil absorbing sponge can help in preventing this in the future. Increase filter cycle time.
	Laundry detergent residual in swimwear	Prevent by running an extra rinse cycle on washing machine or re-rinse well by hand
	Excess organic contaminants	Some organic matter is prone to causing foamy water as it breaks down in the filter (maple leaves especially). Generally using defoamer* to break up the contaminants, then a clarifier* To help filter them away followed by thoroughly cleaning your filter will clear up the problem. It may however be necessary to drain and refill your spa if the foaming is quite excessive.
	Low Calcium Hardness	Test calcium hardness and if necessary increase with calcium chloride*
Corrosion/Etching	Presence of metals in water (iron, copper, etc)	Test total alkalinity levels and if necessary increase with sodium bicarbonate*
Discoloured Water (Clear v. turbid water)	Presence of metals in water (iron, copper, etc)	Treat with chelating* or sequestering agent*
Unstable pH	Low Total Alkalinity levels	Test total alkalinity levels and if necessary increase with sodium bicarbonate*
pH resistant to changing	High Total Alkalinity levels	Test total alkalinity levels and if necessary decrease with sodium bisulfate* or muriatic acid*
		* Contact your local Swimlife retailer for specific product recommendation



ROUTINE SWIM SPA MAINTENANCE

REVIEW CHEMICAL HANDLING SAFETY HINTS

DAILY

- 1 Test water, and if necessary, add shock.
- 2 Ensure proper water level is maintained.

WEEKLY

- 1 Test pH and Alkalinity. Adjust accordingly
- 2 Top-up chemical dispenser
- 3 Add sequesterant (**stain and scale controller**)
- 4 Remove and spray cartridge filter with garden hose and re-install (**see section CARTRIDGE FILTER**)
- 5 Remove and clean out skimmer basket (**see section CLEANING THE SKIMMER BASKET**)
- 6 Add Shock / oxidizing agent
- 7 Inspect union connections for o-ring and gasket leaks - Tighten if loose.

MONTHLY

Soak your filter cartridge in a filter cartridge cleaning solution. Rinse thoroughly and, if possible, allow to dry before re-installing. Swimlife recommends purchasing a second filter so that while the first is cleaning, the other is clean and ready to install

QUARTERLY

At least once per quarter, clean the acrylic shell surface with a non-abrasive cleaner designed specifically for acrylic surfaces.

SAFETY HARD COVER

When a hot tub is uncovered, over 90% of heat is lost from the water surface. This evaporation also affects the chemical balance and could create humidity problems indoors. SWIMLIFE Safety Hard Covers are engineered for maximum thermal efficiency and appearance. They are hinged in the middle for easier handling, and the zip fastener allows the tapered foam inserts to be changed if damaged. The skirt of the safety hard cover hugs the lip of the hot tub for a tight fit. The locks, with one part fastened to the deck or skirt, prevent small children or animals from entering the hot tub. Do not drag the safety hard cover across the hot tub or decking. Standing on the hardcover could cause the tapered foam inserts to crack, which will lead to water absorption.

NEVER LEAN OR STAND ON YOUR HARDCOVER.

The cover should be cleaned at least twice a year with a vinyl moisturizer and protector.

NOTE: ALWAYS ENSURE THE SAFETY HARDCOVER IS IN PLACE AND LOCKED WHENEVER THE HOT TUB IS NOT BEING USED. FAILURE TO DO SO MAY CAUSE DAMAGE OR CRACKING OF THE ACRYLIC SURFACE NOT COVERED UNDER THE WARRANTY.

CLEANING THE SKIMMER BASKET

- 1 Activate the **STANDBY/DRAIN ASSIST** mode
- 2 Remove the skimmer basket by pulling the weir door forward, and pulling the basket up and towards the front
- 3 Remove debris from basket. (**Note: Avoid hitting the basket against objects to knock debris loose as this may damage the unit**)
- 4 Reinsert basket
- 5 Take the system out of **STANDBY/DRAIN ASSIST** mode, and as the pump begins to operate, monitor water flow over the weir door to assure that it is free floating



CARTRIDGE FILTER

The cartridge should be cleaned every two to four weeks, depending on the amount of use. Signs that the filter requires cleaning include:

- **Reduced jet power**
- **Hazy gray water**
- **Rattling noise in the pump or filter**
- **Heater not working**

REMOVAL

- 1 Activate the **STANDBY/DRAIN ASSIST** mode.
- 2 Remove the skimmer cover.
- 3 Pull the basket out.
- 4 Rotate the filter counter clockwise to unthread.
- 5 Lift the filter out of the housing.

CLEANING

- 6 With a garden hose and spray nozzle, hose off the cartridge element, ensuring to carefully separate every pleat.
- 7 To remove collected lotions, body oils, etc. soak the cartridge in warm water and a filter cleaning/emulsifying compound (**available at your SWIMLIFE retailer**).
- 8 A cleaning cylinder may be purchased from your SWIMLIFE Retailer.
- 9 Rinse thoroughly and dry before replacing.
- 10 Swimlife recommends purchasing a spare filter cartridge so that you always have a clean substitute ready to rotate.
- 11 After the element has dried - if necessary, lightly brush between pleats with a fine paint-brush to remove remaining dirt particles.



Do not use a wire brush or other device to clean cartridge element.
Do not put in dishwasher or washing machine.

RE-INSTALLATION

- 12 Place the cartridge filter back into the filter housing.
- 13 Rotate clockwise until the filter is tight in place.
- 14 Reinstall the skimmer tray.
- 15 Locate the skimmer face in place and slide down to lock in place.
- 16 Take the system out of **STANDBY/DRAIN ASSIST** mode.
- 17 When the pump starts circulating on low speed, it will be necessary to release trapped air in the filter.

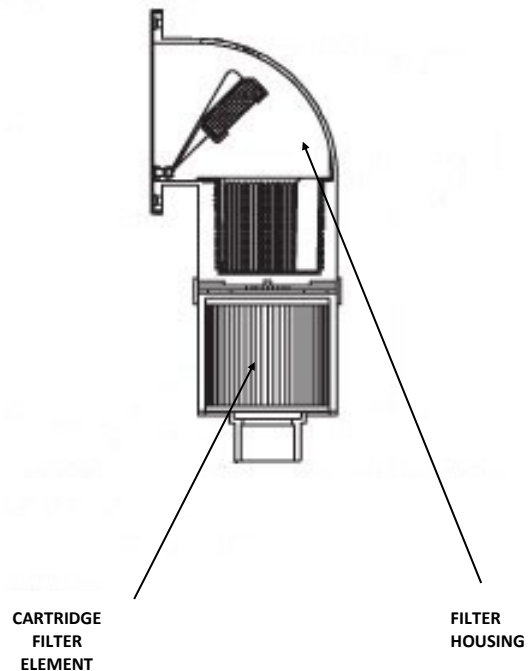

CLEANING THE ACRYLIC SURFACE

The acrylic surface can be cleaned and polished using a soft cloth and acrylic cleaner, available at your Swimlife retailer.



- **Important: Do not use detergents - the remaining residues will adversely affect water chemistry, making it difficult to maintain proper water balance**
- **Do Not use abrasive cleaners – damage to the acrylic surface will occur.**

CHANGING THE SWIM SPA WATER

The water in your swim spa must be carefully monitored and drained regularly as required, depending on size and amount of use. Draining at least once annually is strongly recommended and offers the opportunity for inspection of jets and suction fitting covers. If your swim spa is used daily or by a large number of bathers, the water should be drained more often. One method to determine the approximate length of time between water changes is to divide the water volume (in litres) of your swim spa by 13.5 and then divide by the average number of bathers each day.

Formula

$$\left(\frac{\quad}{13.5} \right) \div \left(\frac{\quad}{\quad} \right) = \left(\frac{\quad}{\quad} \right)$$

Volume of water in litres	Average daily bathers	Days between water changes
------------------------------	-----------------------------	-------------------------------

EXAMPLE:

1000 liters divided by 13.5 divided by 2 = 37 days. The swim spa water must be changed when the amount of dissolved solids becomes excessive, and is usually indicated by "gray" or dull looking water.

DRAINING YOUR SWIM SPA

REFER TO FIGURE 1 & FIGURE 2

- 1 Locate nearest drain facility (**Check your local bylaws**).
- 2 Put the hot tub control system into **STANDBY/DRAIN ASSIST** mode. The system will automatically exit Standby Mode after 1 hour and resume normal operating functions.
- 3 Remove the skimmer basket so that the hole beneath it is accessible, and insert the #10 rubber expansion plug provided.
- 4 Attach garden hose to hose bib located on plumbing line beside the hot tub control system.
- 5 Run garden hose to drain location.
- 6 Open hose bib.
- 7 Close filtration pump return gate valve next to the hose bib (this directs the water out the drain hose).
- 8 Activate the circ pump.
- 9 Monitor the swim spa while it drains.
- 10 Use the second garden hose to wash down interior surface as the swim spa continues to drain. A sponge may also be used to wipe down the interior surface.

WATER SOFTENERS

Never fill a swim spa with water from a water softener, as it could adversely effect the water chemistry, making it difficult to maintain proper water balance. If you live in an area with hard or soft water, give careful attention to your Calcium Hardness level. Topping up with soft water is acceptable.

- 11 To completely flush the old water from the plumbing lines: allow fresh water to fill into the foot-well area while the old water continues to be pumped out. Always keep at least 10 cm (4 in.) of water in the foot-well so that pump 1 remains primed.
- 12 When the water from the drain hose turns clear (indicating fresh fill water), flush is complete.
- 13 Turn OFF the filtration pump.
- 14 Close the drain-hose bib on the swim spa plumbing line and continue filling swim spa with fresh water.
- 15 Place cover on swim spa (to avoid splash-out).
- 16 Open filtration pump return gate valve.
- 17 Press any button on the topside control panel (other than the pump 1 button) to take the system out of **STANDBY/DRAIN ASSIST** mode. Filtration pump and the heater will activate to circulate and heat the water while filling continues. This also reduces the possibility of an airlock occurring.
- 18 Continue adding fresh fill water until level is approximately 19mm (3/4 in.) from the top of the skimmer opening.
- 19 Once fill is complete, remove the #10 rubber expansion plug from the bottom of the skimmer housing.*
- 20 If the filter housing was opened to replace the cartridge filter, it will be necessary to release trapped air from the filter housing by carefully loosening the small black air vent/bleeder valve located on the top of the filter housing. When water begins to escape close the air vent valve.
- 21 In the unlikely event of a pump air lock (pump 1 is operating but there is no water movement from the jets), refer to section **PUMP PRIMING/RELEASING AN AIR LOCK**

* It may be necessary to put system into **STANDBY/DRAIN ASSIST* mode in order to remove plug.**



FIGURE 1

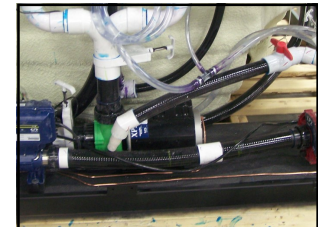

FIGURE 2

TRICHLOR WATER TREATMENT

TriChlor tablets dissolve very fast in comparison to Bromine tablets and also decreases the pH levels. TriChlor is commonly used in swimming pools and is added to the water using an in-line chlorinator, feeder or floating feeder. Trichlor should not be used in spas and swim spas due to its corrosive nature and due to the adverse affects it can have on the pumps, jets and acrylic surface. Since many chlorine tabs or pucks contain TriChlor, we do not recommend the use of them in any form and in most cases this will void the warranty.

SOFT STRIDE FLOOR SYSTEM

The exclusive Soft Stride Floor System is available as a standard feature on the 12SL, 14SL and 17SL models to provide a better grip, traction and comfort on both the steps and floor of the swim spa. Making your swim spa safe and easy to use while getting in and out.

Care & Maintenance Recommendations:

- Soft Stride Floor System cleans easily with soap, hot water and a brush (soft to medium bristle stiffness). Chlorine/bleach and water mixture, isopropyl rubbing alcohol or other household cleaners such as SoftScrub, Simply Green and 409 can be used to clean the pads.
- Be sure any soap or cleaning product is thoroughly rinsed from the pads and swim spa shell and this residue is removed before refilling the spa to prevent foaming.
- Always promptly attend to and clean any noticeable stains.

Never:

- Allow coloured anti-freeze to puddle or dry on the mat.
- Allow stains to develop without promptly being attended to and cleaned.
- Clean with acid based cleanly products.
- Use acetone or mineral spirits on the pads or swim spa shell as damage caused to the swim spa shell from these chemicals will void the warranty.

CARE OF STAINLESS STEEL

Swimlife uses stainless steel in a number of our swim spas. Its lasting beauty and resistance to corrosion make it an excellent material for handrails and jet faces.

With the proper care it will keep its luster for many years. All stainless steel can corrode given the right circumstances so we have provided a guide to help you keep the stainless components in your swim spa looking nice.

Stainless steel derives its ability to resist corrosion by forming a very thin transparent coating on the surface when exposed to oxygen. This coating can be damaged by abrasive materials such as steel wool, sand paper, and other cleaning materials that are abrasive. Chlorine salts, sulfides or other rusting metals can also erode this thin coating exposing the metal to corrosion.

The best defense to combat corrosion on stainless steel components in your swim spa is to make sure that it is kept clean and free of any chemical build up.

Always:

- Clean frequently with fresh, clean water.
- Remove any rust spots as soon as they appear with vinegar or a brass, silver, or chrome cleaner.
- Use a good car cleaning wax for extra protection

Never:

- Clean with mineral acids or bleaches.
- Clean with steel wool or any other abrasive material.
- Leave in contact with iron, steel or other metals.
- Close the cover immediately after adding chemicals to the water.

NOTE: Failure to take proper care of the stainless steel components could result with them rusting. Rusting is not covered by the warranty.

Do not cover the swim spa for 15 minutes after adding chemicals as the off gas can cause unwarranted damage. Larger dosages can require longer lengths of time to off gas. It is recommended to check the swim spa water more frequently to allow small dosages to be added as necessary versus large dosages being added less often.

WINTERIZING YOUR SWIMLIFE SWIM SPA

In the event that you do not wish to use your swim spa year-round, it is very important that you properly winterize it to protect against damage from freezing. Your **SWIMLIFE** retailer can perform this service for a nominal fee. If you choose to winterize your swim spa yourself, please follow the directions outlined below:

1. Drain the swim spa tub entirely. See section - **DRAINING YOUR SWIM SPA**.
2. Remove and clean the filter cartridge. See section - **CARTRIDGE FILTER**.
3. Remove all of the jet inserts that are removable, any suction covers, water diverter cap(s) and waterfall control valve cap(s).
4. Using a wet / dry utility vacuum, remove remaining water from the jet openings, filter cartridge housing and footwell.
5. Using the blower side of the vacuum, position the blower nozzle into the top of the water diverter cap to blow out any water remaining in the plumbing lines so that the excess water will come out the jet bodies.
6. Replace all of the water diverter caps and waterfall control valve caps ensuring all gaskets are in place.
7. At the equipment end, loosen one union from each pump so that any excess water in each pump can be vacuumed out completely.
8. Either pour or use a turkey baster where necessary to add potable biodegradable RV antifreeze to areas such as pump wet ends, jet channels, filter housing and any blower channels.
9. Reinstall all jet inserts and all suction covers.

DO NOT USE AUTOMOTIVE ANTIFREEZE.

- **Important:** mixing potable biodegradable RV antifreeze with water significantly reduces its ability to protect against freezing. Therefore, it is very important ALL water is removed from the hot tub plumbing before adding.
- Add potable RV antifreeze to the holes in the bottom suction/drain to prevent any trapped water in the false floor from freezing and damaging the hot tub shell.
- Turn pump on for only a few seconds to circulate the antifreeze.
- Cover exposed plumbing connections with plastic bags and duct tape.
- Where practical, disconnect swim spa support equipment and store in a dry heated area.
- Install the safety hardcover, and cover the entire hot tub with a tarp to prevent premature weathering of the cabinet and the safety hard cover.
- Remove snow build up regularly to prevent damage to the safety hard cover.
- It is assumed that your **SWIMLIFE** swim spa has been properly installed on a reinforced concrete pad to eliminate lifting of the hot tub due to hydrostatic ground water pressure.



DRAIN PLUG LOCATIONS

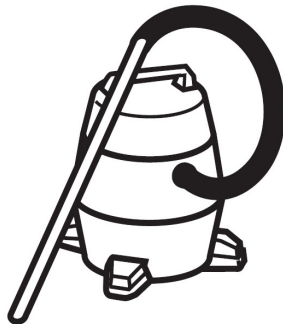

If you are not 100% confident that your hot tub is properly winterized, please consult your authorized **SWIMLIFE** Hot Tub Retailer. Caution recommends that an authorized Swirlife Retailer winterize your hot tub in the initial year. Damage as a result of freezing is not covered by the warranty.

GENERAL TROUBLESHOOTING CONTINUED

WHAT TO DO IN THE EVENT OF...

...POWER FLUCTUATIONS

The power supply into your home is, for the most part, fairly consistent.

However, when local power demand is high, there is a tendency for the voltage entering your home to drop (sometimes significantly) or fluctuate.

This condition is referred to as a 'brown-out'. Although safeguards have been built into the system to protect against this condition, supply voltage may drop low enough, if even for a second, to cause the system to display a 'ghost' message. Should this occur or if the display shows partial messages, try resetting the system by turning power to the swim spa, waiting a few minutes, then turning power on again. If this does not reset the system, contact your local Swimlife retailer or service organization.

...POWER FAILURE OR SYSTEM FAULT DURING COLD WEATHER CONDITIONS

If your control system will not reset, (ie. GFCI trips) or if your pump will not circulate for any other reason, place a low wattage space heater under the cabinet in the equipment area. This will delay the risk of freezing while a service appointment is scheduled.



Always follow the manufacturers instructions when locating and placing a portable electric space heater into service. Ensure that safe clearance to combustible surfaces is maintained. Do not leave unattended.

NOTES:

IN.YE-3 NA WIRING DIAGRAM

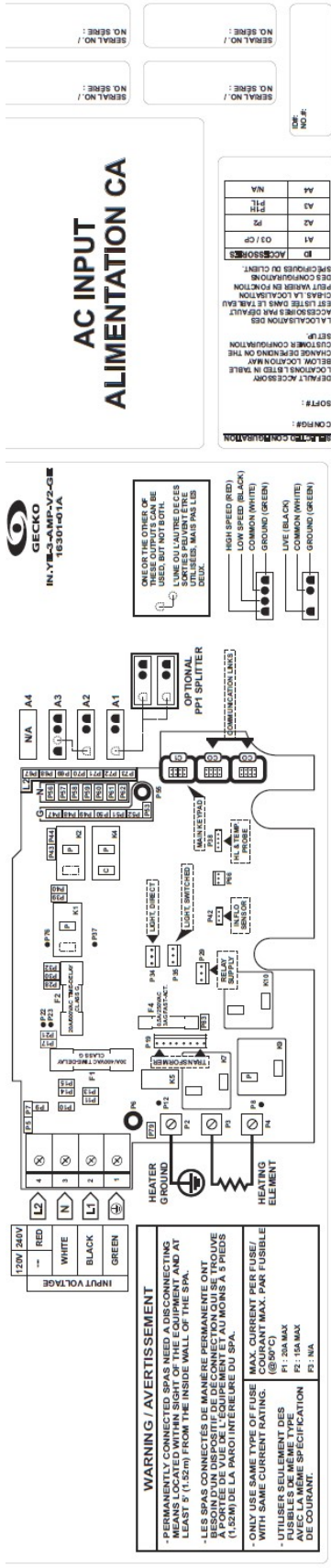

AC INPUT ALIMENTATION CA

GECKO IN.YE-3-AMP-V2-GE 183330101A

ONE OR THE OTHER OF THE FOLLOWING WIRING METHODS MUST BE USED. ONLY ONE WIRE FROM EACH SET SHOULD BE USED. UNLESS OTHERWISE SPECIFIED, Wires MUST BE USED AS SHOWN.

HAUTE VITESSE (ROUGE)
 BASSE VITESSE (NOIR)
 COMMUN (BLANC)
 MISE À LA TERRE (VERT)

DEFULT ACCESSORY CONNECTIONS
 1. LOCATION DES ACCESSOIRES DANS LE TABLEAU DE MONTAGE
 2. CHANGEMENTS DE CONNEXION
 3. CHANGEMENTS DE CONNEXION
 4. CHANGEMENTS DE CONNEXION
 5. CHANGEMENTS DE CONNEXION
 6. CHANGEMENTS DE CONNEXION
 7. CHANGEMENTS DE CONNEXION
 8. CHANGEMENTS DE CONNEXION
 9. CHANGEMENTS DE CONNEXION
 10. CHANGEMENTS DE CONNEXION

WARNING
 -FOR PROPER GROUNDING, GREEN WIRES MUST BE CONNECTED TO A GROUND TERMINAL ON THE PCB.
 -ALL OUTPUT FACTORY SHIPPED AS 240V.
 -ALL OUTPUTS MUST BE CONFIGURED AS 120V BY PLUGGING THEIR RESPECTIVE WHITE WIRES TO ANY N TERMINAL ON THE PCB.
 -ADDITIONAL WHITE WIRES TO ANY N TERMINAL ON THE PCB ARE CONFIGURED AS 240V BY PLUGGING THEIR RESPECTIVE WHITE WIRES TO ANY L2 TERMINAL ON THE PCB.

AVERTISSEMENT
 -POUR LA MISE À LA TERRE, LES FILS VERTS DOIVENT ÊTRE CONNECTÉS À UN CONNECTEUR D DE LA CARTE ÉLECTRONIQUE.
 -TOUTS LES ACCESSOIRES FOURNIS EN 240V PAR DÉFAUT.
 -TOUTS LES SORTIES SONT CONFIGURABLES 120V EN CONNECTANT LES FILS BLANCS À N'IMPORTE QUEL CONNECTEUR N DE LA CARTE ÉLECTRONIQUE.
 -LES SORTIES BLANCS À N'IMPORTE QUEL CONNECTEUR L2 DE LA CARTE ÉLECTRONIQUE SONT CONFIGURÉS 240V.

CONNECTION ID	WIRE COLOR	WIRE TYPE	WIRE GAUGE	WIRE LENGTH	WIRE TYPE	WIRE GAUGE	WIRE LENGTH
A1	BLACK	N2P	P40	OUT 4	F2		
A2	BLACK	N2P	(SHARED)	OUT 5	F2		
A3	RED	N4P	(SHARED)	OUT 2	F1		
A4	BLACK	N4P	(SHARED)	OUT 1	F1		
A4	N/A	N/A	N/A	N/A	N/A		

MANDATORY CONNECTIONS
 N/A
 N/A
 N/A

MODEL / MODÈLE :
 IN.YE-3-AMP-V2-GE

OPTIONS :
 NONE

INPUT / ENTRÉE :
 120V / 240V

ID NUMBER / NO. PRODUIT :
 183330101A

SERIAL NO. / NO. SÉRIE :
 N/A

MADE IN MEXICO

***** Pour toute modification, vérifier si des changements aux instructions d'assemblage sont à faire. *****

REV	ORIGINAL	DATE	APR 16 2018	BY	C.C.
REV	REVISION	DATE		BY	
		FIGURE NO.	1830101A		
4650, Ocas Court Chubbuck, (Quebec)		ISSUE DATE	APR 05 2018		
TEL: (418) 872-4411 FAX: (418) 872-0588		CONDUCTOR	CORELDMMY 17		
DESCRIPTION WIRING DIAGRAM IN.YE-3-AMP-V2-GE		DATE	APR 05 2018		
DRAWN BY: C.OWEN CHECKED BY: C.OWEN		DATE			
APPROVED BY:		DATE			
SCALE:		NUMBER OF PAGES	FOUR (4)		
SHEET NO. 1		FOUR (4)			

IN.YE-5 EU WIRING DIAGRAM

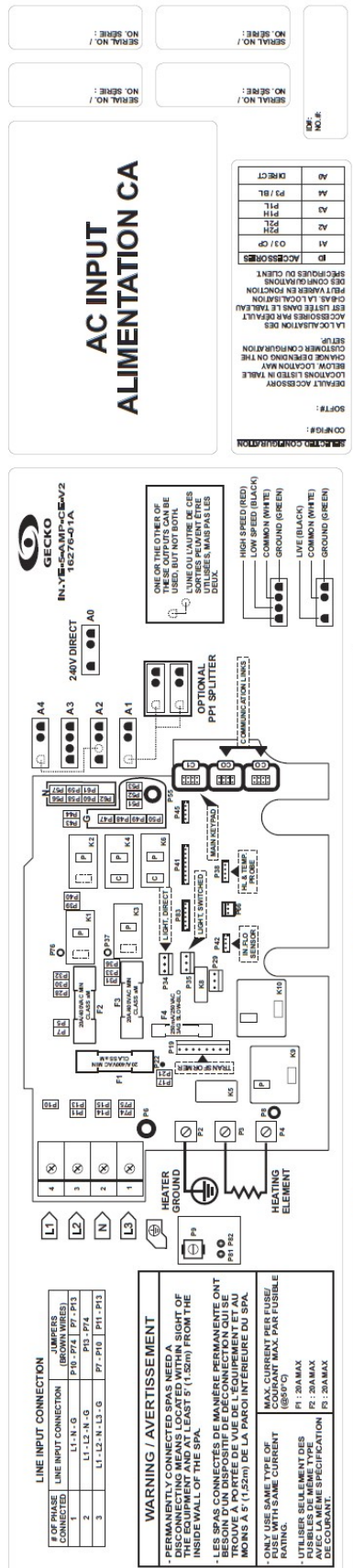

AC INPUT ALIMENTATION CA

WIRE	WIRE COLOR	WIRE NUMBER	WIRE NUMBER
1	BLACK	164P	OUT 2
2	RED	165P	OUT 1
3	BLACK	166P	OUT 3
4	BLACK	167P	OUT 4
5	BLACK	168P	OUT 5
6	BLACK	169P	OUT 6
7	BLACK	170P	OUT 7
8	BLACK	171P	OUT 8
9	BLACK	172P	OUT 9
10	BLACK	173P	OUT 10
11	BLACK	174P	OUT 11
12	BLACK	175P	OUT 12
13	BLACK	176P	OUT 13
14	BLACK	177P	OUT 14
15	BLACK	178P	OUT 15
16	BLACK	179P	OUT 16
17	BLACK	180P	OUT 17
18	BLACK	181P	OUT 18
19	BLACK	182P	OUT 19
20	BLACK	183P	OUT 20
21	BLACK	184P	OUT 21
22	BLACK	185P	OUT 22
23	BLACK	186P	OUT 23
24	BLACK	187P	OUT 24
25	BLACK	188P	OUT 25
26	BLACK	189P	OUT 26
27	BLACK	190P	OUT 27
28	BLACK	191P	OUT 28
29	BLACK	192P	OUT 29
30	BLACK	193P	OUT 30
31	BLACK	194P	OUT 31
32	BLACK	195P	OUT 32
33	BLACK	196P	OUT 33
34	BLACK	197P	OUT 34
35	BLACK	198P	OUT 35
36	BLACK	199P	OUT 36
37	BLACK	200P	OUT 37
38	BLACK	201P	OUT 38
39	BLACK	202P	OUT 39
40	BLACK	203P	OUT 40
41	BLACK	204P	OUT 41
42	BLACK	205P	OUT 42
43	BLACK	206P	OUT 43
44	BLACK	207P	OUT 44
45	BLACK	208P	OUT 45
46	BLACK	209P	OUT 46
47	BLACK	210P	OUT 47
48	BLACK	211P	OUT 48
49	BLACK	212P	OUT 49
50	BLACK	213P	OUT 50
51	BLACK	214P	OUT 51
52	BLACK	215P	OUT 52
53	BLACK	216P	OUT 53
54	BLACK	217P	OUT 54
55	BLACK	218P	OUT 55
56	BLACK	219P	OUT 56
57	BLACK	220P	OUT 57
58	BLACK	221P	OUT 58
59	BLACK	222P	OUT 59
60	BLACK	223P	OUT 60
61	BLACK	224P	OUT 61
62	BLACK	225P	OUT 62
63	BLACK	226P	OUT 63
64	BLACK	227P	OUT 64
65	BLACK	228P	OUT 65
66	BLACK	229P	OUT 66
67	BLACK	230P	OUT 67
68	BLACK	231P	OUT 68
69	BLACK	232P	OUT 69
70	BLACK	233P	OUT 70
71	BLACK	234P	OUT 71
72	BLACK	235P	OUT 72
73	BLACK	236P	OUT 73
74	BLACK	237P	OUT 74
75	BLACK	238P	OUT 75
76	BLACK	239P	OUT 76
77	BLACK	240P	OUT 77
78	BLACK	241P	OUT 78
79	BLACK	242P	OUT 79
80	BLACK	243P	OUT 80
81	BLACK	244P	OUT 81
82	BLACK	245P	OUT 82
83	BLACK	246P	OUT 83
84	BLACK	247P	OUT 84
85	BLACK	248P	OUT 85
86	BLACK	249P	OUT 86
87	BLACK	250P	OUT 87
88	BLACK	251P	OUT 88
89	BLACK	252P	OUT 89
90	BLACK	253P	OUT 90
91	BLACK	254P	OUT 91
92	BLACK	255P	OUT 92
93	BLACK	256P	OUT 93
94	BLACK	257P	OUT 94
95	BLACK	258P	OUT 95
96	BLACK	259P	OUT 96
97	BLACK	260P	OUT 97
98	BLACK	261P	OUT 98
99	BLACK	262P	OUT 99
100	BLACK	263P	OUT 100

MODEL / MODELE :
OPTIONS :
ID NUMBER / NO. PRODUIT :
INPUT / ENTRÉE :

MADE IN MEXICO

DEFALCT ACCESSORY LOCATION MAY CHANGE DEPENDING ON THE CUSTOMER CONFIGURATION SET UP.

LA CARRIÈRE DES ACCESSOIRES PEUT VARIER EN FONCTION DES CONFIGURATIONS CLIENTS. VÉRIFIER LA CARTE D'IDENTIFICATION ET LISTER DANS LE TABLEAU DES ACCESSOIRES PAR DÉFAUT.

CHANGING THE ORDER OF THESE OUTPUTS CAN BE DONE BY USING THE CUSTOMER CONFIGURATION SWITCH.

CHANGER L'ORDRE DES SORTIES PEUT ÊTRE FAIT EN UTILISANT LE COMMANDEUR EN OPTION.

UNLESS THE OTHERS OF THESE OUTPUTS CAN BE USED, BUT NOT BOTH. (UNE OU LAUTRE DE CES SORTIES NE PEUT ÊTRE UTILISÉE, MAIS PAS LES DEUX.)

HIGH SPEED (RED)
LOW SPEED (BLACK)
COMMON (WHITE)
GROUND (GREEN)

LIVE (BLACK)
COMMON (WHITE)
GROUND (GREEN)

HEATER ELEMENT
HEATER ELEMENT

HEATER GROUND

OPTIONAL PPT SWITCH

240V DIRECT

AO A1 A2 A3 A4

WARNING / AVERTISSEMENT
- PERMANENTLY CONNECTED SPAS NEED A DISCONNECTING MEANS LOCATED WITHIN SIGHT OF THE USER AND WITHIN REACH OF THE USER.
- LES SPAS CONNECTÉS DE MANIÈRE PERMANENTE ONT BESOIN D'UN DISPOSITIF DE DÉCONNEXION QUI SE TROUVE À PORTÉE DE VUE DE L'ÉQUIPEMENT ET AU MOINS À 5' (1.52m) DE LA PARTIE INTÉRIEURE DU SPA.
- ONLY USE SAME TYPE OF FUSIBLES WITH SAME CURRENT RATING.
- UTILISER SEULEMENT DES FUSIBLES DE MÊME TYPE AVEC MÊME TYPE DE COURANT.
MAX. CURRENT PER FUSE / FUSIBLE MAX. PAR FUSIBLE (600V)
P1: 20A MAX P7: 20A MAX
P2: 20A MAX P3: 20A MAX

LINE INPUT CONNECTION

WIRE	WIRE COLOR	WIRE NUMBER	WIRE NUMBER
1	BLACK	164P	OUT 2
2	RED	165P	OUT 1
3	BLACK	166P	OUT 3
4	BLACK	167P	OUT 4
5	BLACK	168P	OUT 5
6	BLACK	169P	OUT 6
7	BLACK	170P	OUT 7
8	BLACK	171P	OUT 8
9	BLACK	172P	OUT 9
10	BLACK	173P	OUT 10
11	BLACK	174P	OUT 11
12	BLACK	175P	OUT 12
13	BLACK	176P	OUT 13
14	BLACK	177P	OUT 14
15	BLACK	178P	OUT 15
16	BLACK	179P	OUT 16
17	BLACK	180P	OUT 17
18	BLACK	181P	OUT 18
19	BLACK	182P	OUT 19
20	BLACK	183P	OUT 20
21	BLACK	184P	OUT 21
22	BLACK	185P	OUT 22
23	BLACK	186P	OUT 23
24	BLACK	187P	OUT 24
25	BLACK	188P	OUT 25
26	BLACK	189P	OUT 26
27	BLACK	190P	OUT 27
28	BLACK	191P	OUT 28
29	BLACK	192P	OUT 29
30	BLACK	193P	OUT 30
31	BLACK	194P	OUT 31
32	BLACK	195P	OUT 32
33	BLACK	196P	OUT 33
34	BLACK	197P	OUT 34
35	BLACK	198P	OUT 35
36	BLACK	199P	OUT 36
37	BLACK	200P	OUT 37
38	BLACK	201P	OUT 38
39	BLACK	202P	OUT 39
40	BLACK	203P	OUT 40
41	BLACK	204P	OUT 41
42	BLACK	205P	OUT 42
43	BLACK	206P	OUT 43
44	BLACK	207P	OUT 44
45	BLACK	208P	OUT 45
46	BLACK	209P	OUT 46
47	BLACK	210P	OUT 47
48	BLACK	211P	OUT 48
49	BLACK	212P	OUT 49
50	BLACK	213P	OUT 50
51	BLACK	214P	OUT 51
52	BLACK	215P	OUT 52
53	BLACK	216P	OUT 53
54	BLACK	217P	OUT 54
55	BLACK	218P	OUT 55
56	BLACK	219P	

IN.YE-5 NA WIRING DIAGRAM

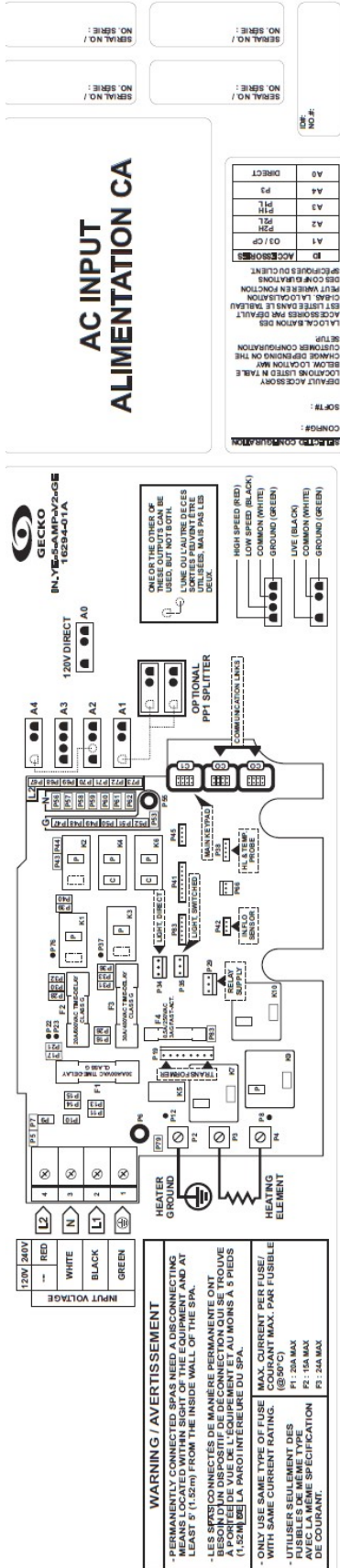

AC INPUT ALIMENTATION CA

ACCESORIES	NO. PRODUCT
A0	DIRECT
A1	Q3 / Q4
A2	P21
A3	P22
A4	P23

MODEL / MODELE :
OPTIONS :
INPUT / ENTREE :

MADE IN MEXICO

***** Pour toute modification, vérifier si des changements aux instructions d'assemblage sont à faire. *****

GECKO
WIRING DIAGRAM
IN.YE-5AMP-V2-GE

DESCRIPTION: WIRING DIAGRAM IN.YE-5AMP-V2-GE
DESIGNED BY: GLOHAMA
DATE: MAR. 31, 2016

REVISION: ORIGINAL
DATE: MAR 16 16 294-D1A

PROJECT NAME: MAR. 31, 2016
CONTRACTOR: GECKO (USA)
TAL: (415) 872-4411
FAX: (415) 872-0920

DATE: MAR 16 16 294-D1A
REV: 1
APP: []

NUMBER: 16294-D1A
PROJECT NAME: []
DATE: []
REV: []
APP: []

WARNING
- ALL OUTPUTS (EXCEPT A0) FACTORY SHIPPED AS 240V.
- ALL ACCESSORIES (EXCEPT A0) FACTORY SHIPPED AS 240V BY PLUGGING BLANK RESPECTIVE WHITE WIRES TO ANY N TERMINAL ON THE PCB.
- ALL OUTPUTS MUST BE CONFIGURED AS 240V BY PLUGGING THEIR RESPECTIVE WHITE WIRES TO ANY L2 TERMINAL ON THE PCB.

AVERTISSEMENT
- TO A G TERMINAL ON THE PCB.
- TOUS LES ACCESSOIRES SAUF A0 CONFIGURÉS EN 240V PAR DÉFAUT.
- TOUS LES ACCESSOIRES SAUF A0 SONT CONFIGURÉS EN 240V PAR DÉFAUT EN BLANCS À L'IMPORTE QUEL CONNECTEUR N DE LA CARTE ÉLECTRONIQUE.
- TOUTES LES SORTIES SONT CONFIGURABLES 240V EN CONNECTANT LES FILS BLANCS À N'IMPORTE QUEL CONNECTEUR L2 DE LA CARTE ÉLECTRONIQUE.